

Glendale Community College
William Abraamyan

WILLIAM ABRAAMYAN

ARCHITECTURAL PORTFOLIO
GLENDALE COMMUNITY COLLEGE



SKILLS

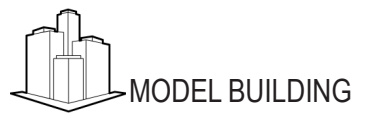

CONTENTS

LITTLE TOKYO PARK TOWER.....4

MACARTHUR PARK MIX USE BUILDING.....16

HOUSE FOR A BLIND PERSON.....28

Glendale Community College
William Abraamyan



LITTLE TOKYO PARK TOWER

401 E. 1ST ST.
LOS ANGELES, CA



THE LITTLE TOKYO PARK TOWER IS A FUTURISTIC DESIGN THAT WOULD BE MADE POSSIBLE BY THE STANDARDIZATION OF CLEAN AIR, ELECTRIC VEHICLES TO AVOID FUMES AND NOISE.

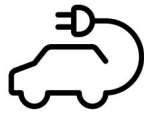

THE DESIGN WAS INSPIRED BY THE IDEA OF MAKING TRAVEL AND PARKING AS EFFICIENT AS POSSIBLE. WITH THE INTEGRATED PARKING LEVELS, PEDESTRIANS ARE ABLE TO DRIVE STRAIGHT TO THEIR DESIRED DESTINATION, CREATING EFFICIENCY AND EIMINATING FOOT TRAFFIC.

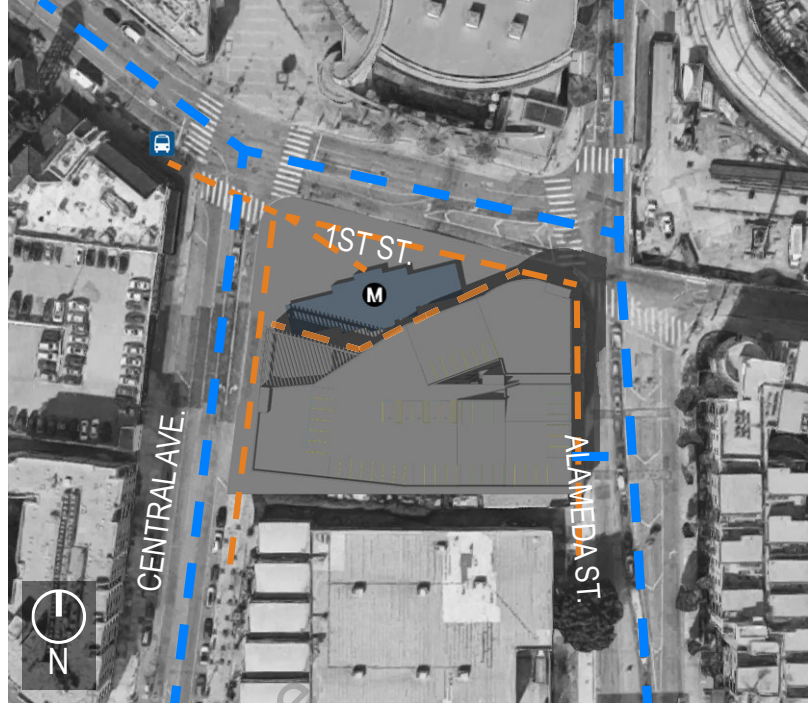

PARTI

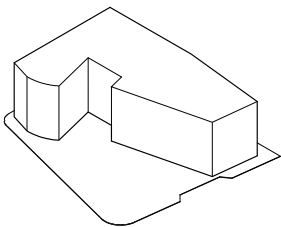

BASIC SHAPE

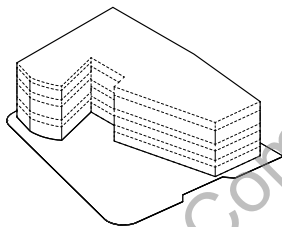

SUBTRACT VOLUME FOR PARKING

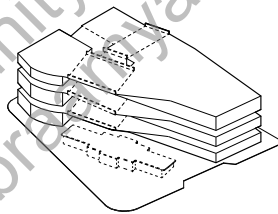

ADD CONNECTING RAMPS

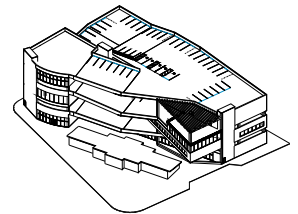

FINAL DETAILING

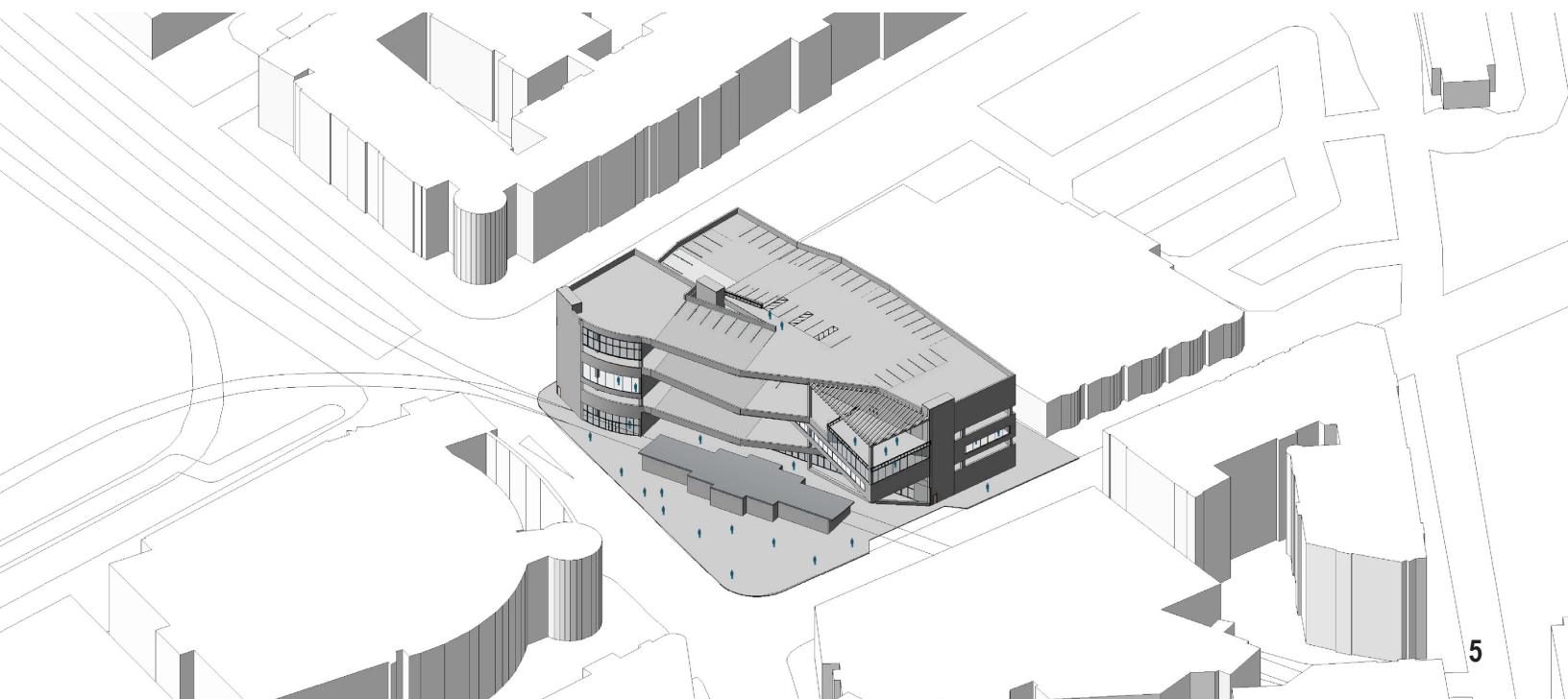

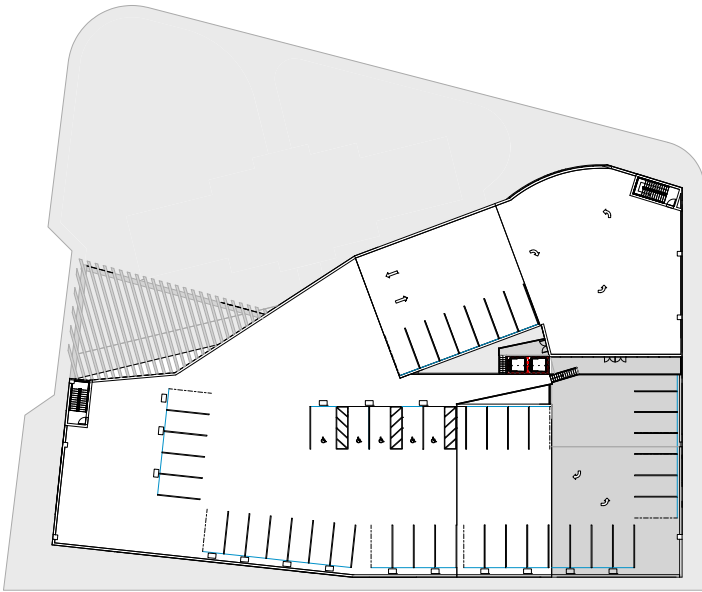

PARKING LEVEL 5

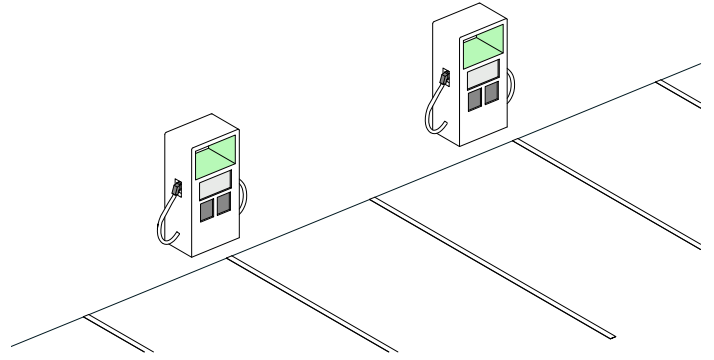

E.V. CHARGING STATIONS AT PARKING SPOTS

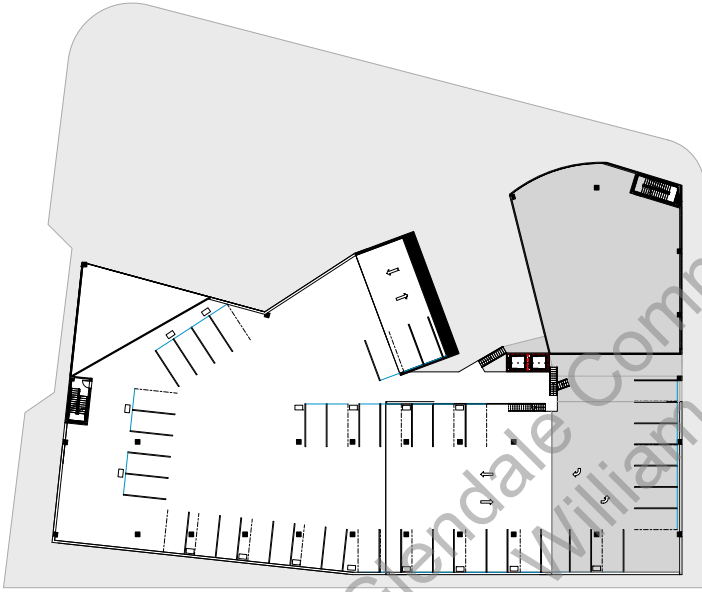

PARKING LEVEL 3

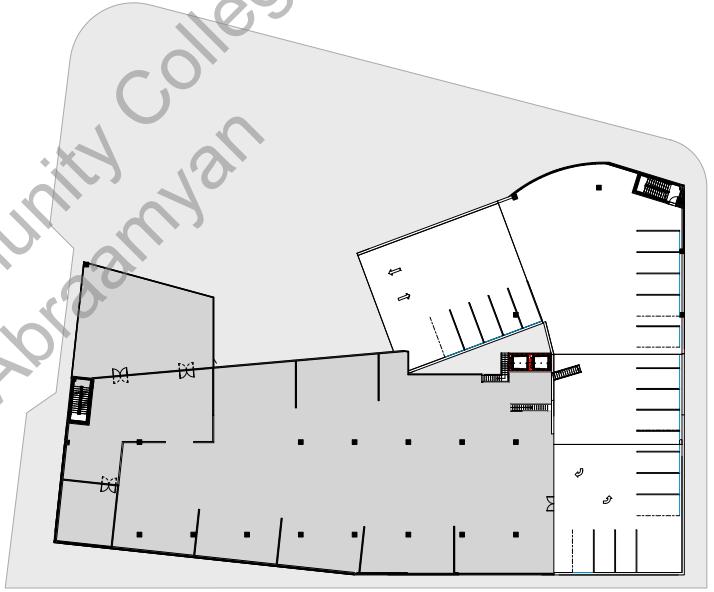

PARKING LEVEL 4

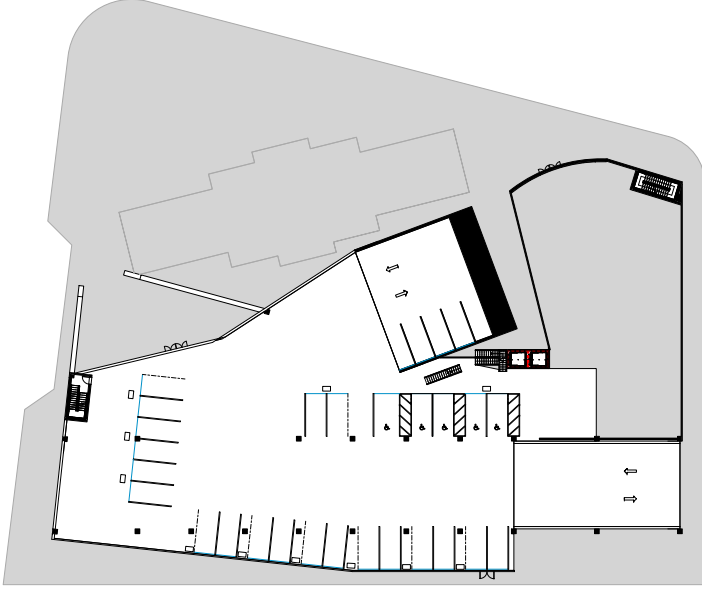

PARKING LEVEL 1

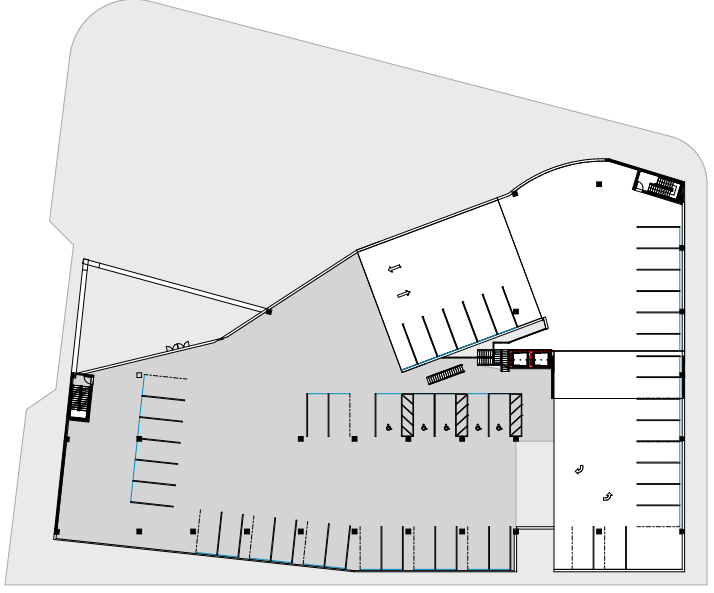

PARKING LEVEL 2

VEHICULAR
CIRCULATION

PARKING LEVEL 5

PARKING LEVELS
3 - 4

PARKING LEVELS
1 - 2

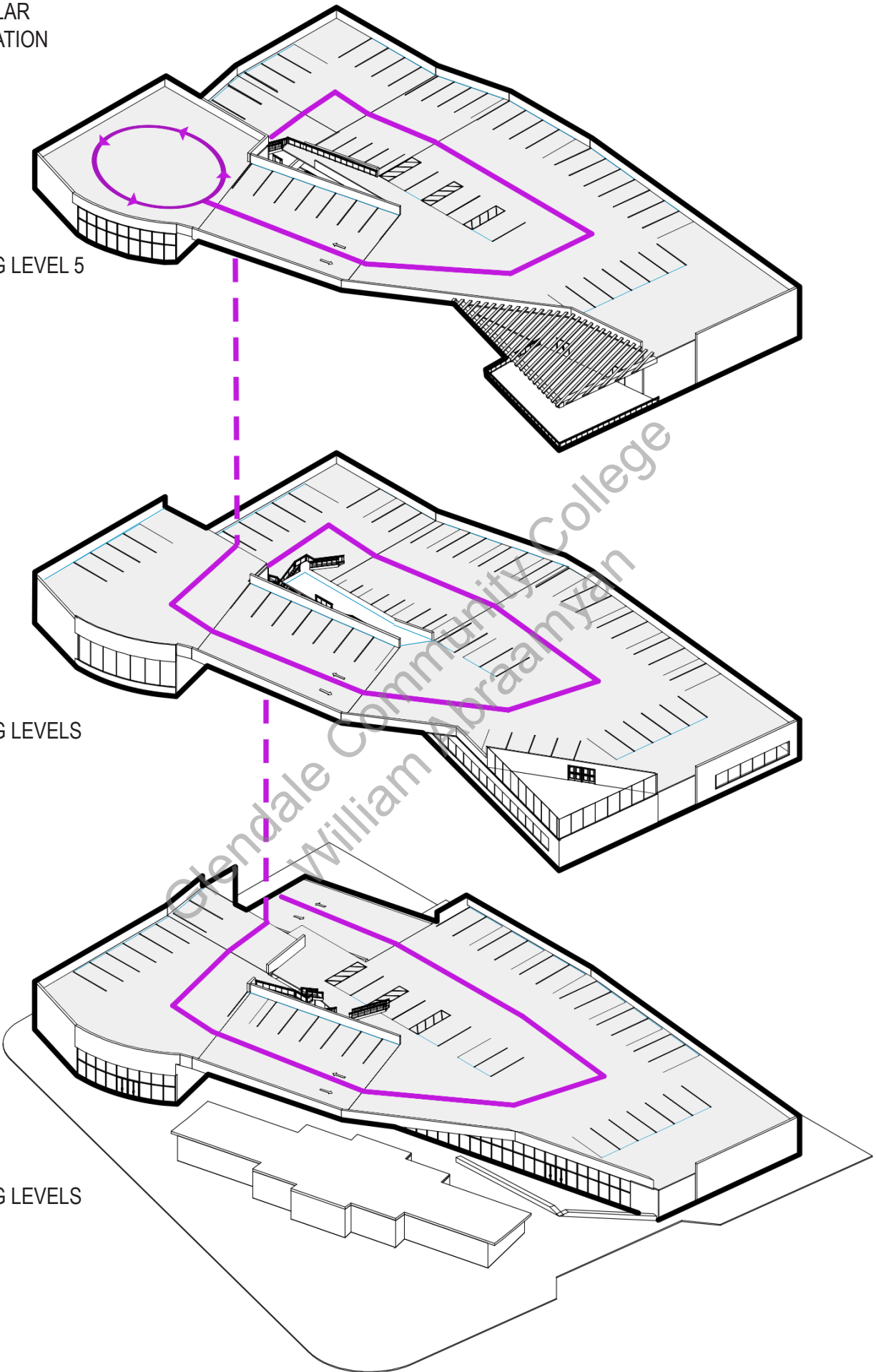

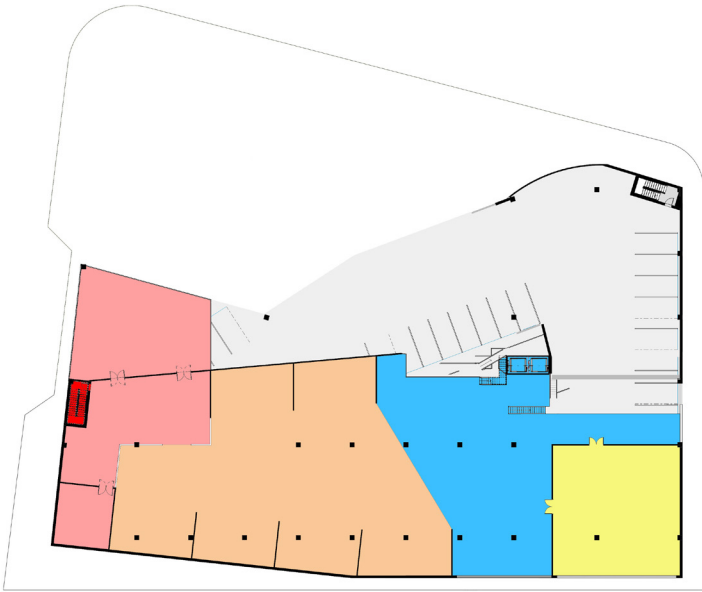

LEVEL 3

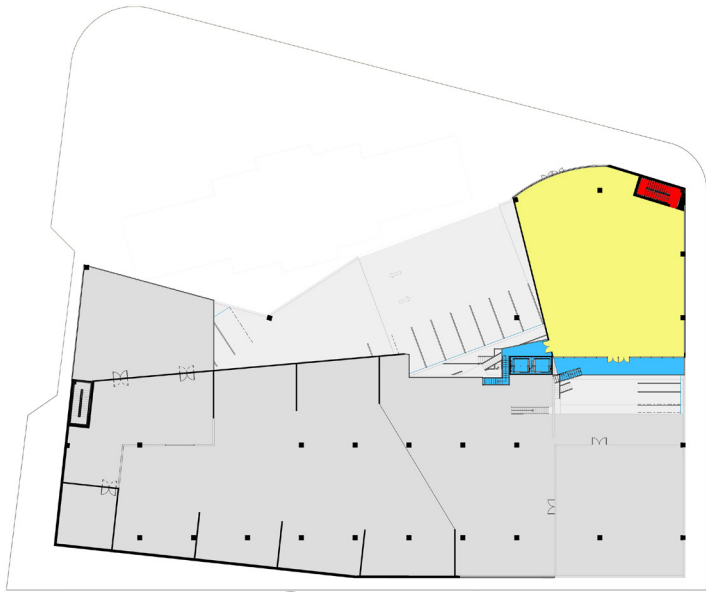

LEVEL 4

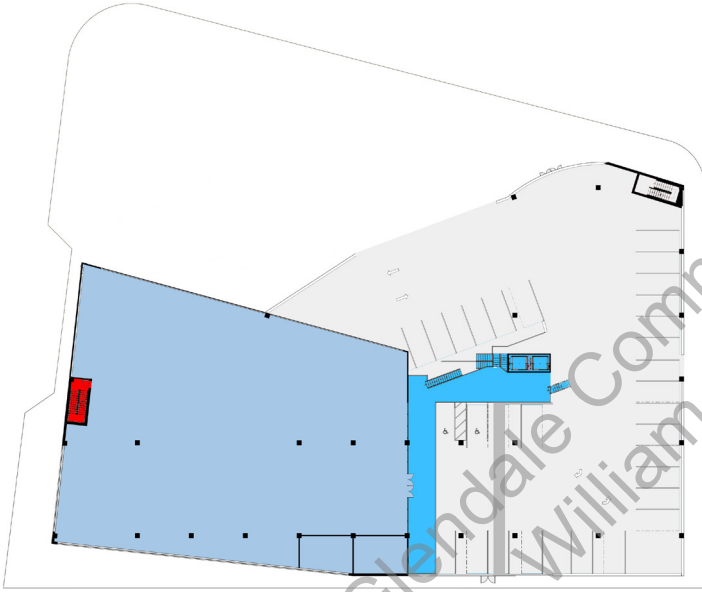

LEVEL 1

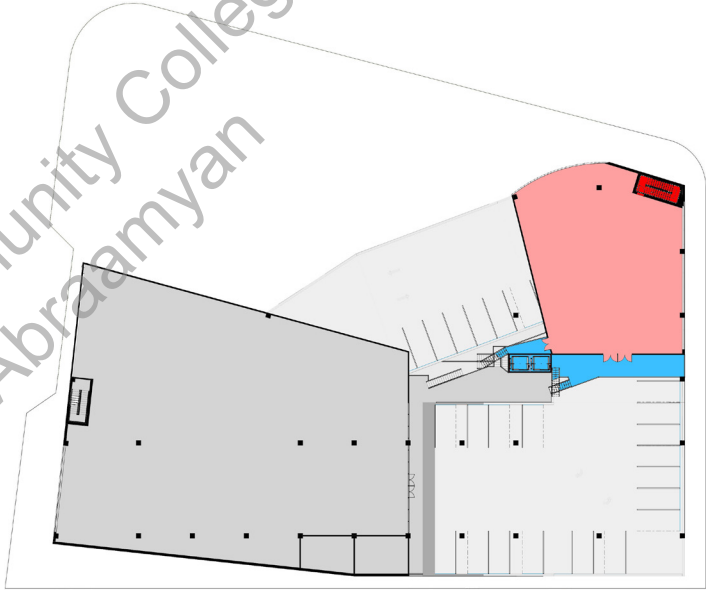

LEVEL 2

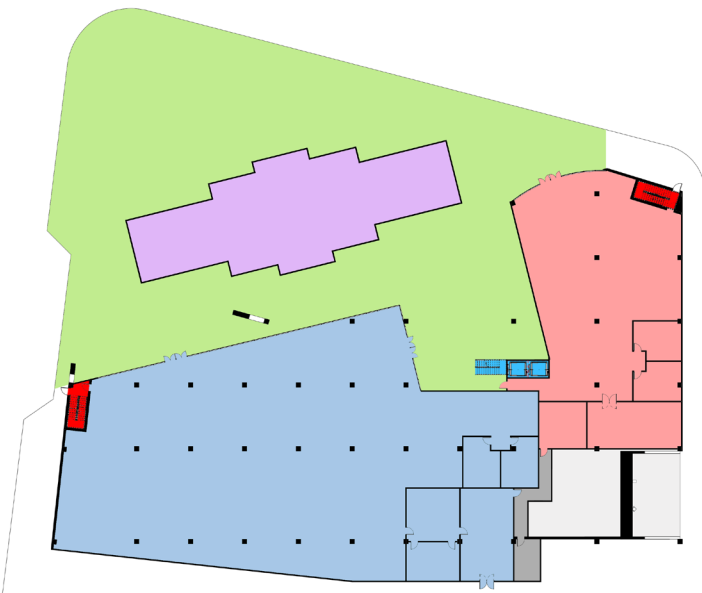

GROUND FLOOR

LEGEND

- GREEN AREA
- METRO STATION
- RETAIL SPACE
- RESTAURANT
- FOOD COURT
- OFFICE SPACE
- CIRCULATION
- FIRE ESCAPE
- TRASH ENCLOSURE

CIRCULATION
DIAGRAM

LEVELS 3 - 4

LEVELS 1 - 2

GROUND LEVEL

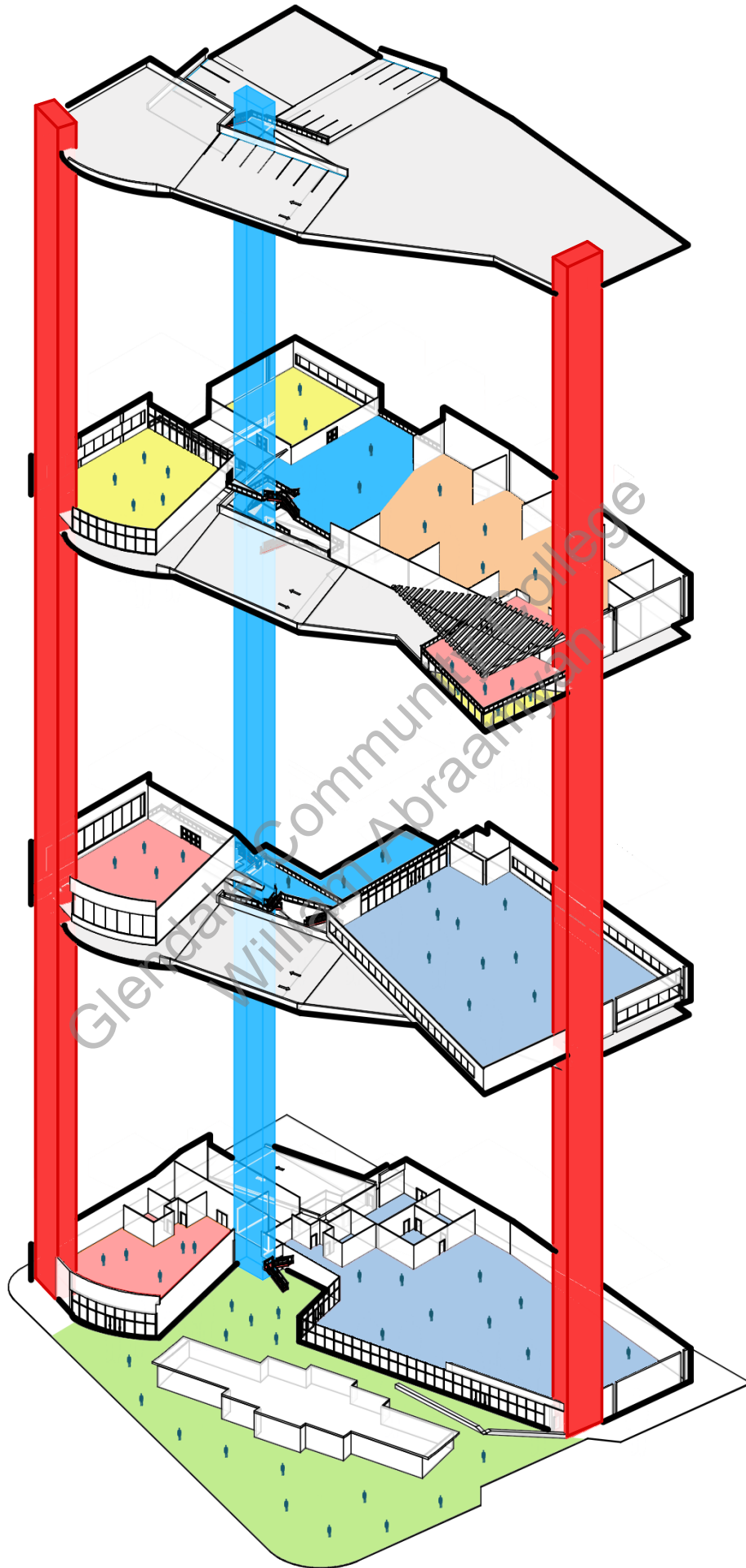

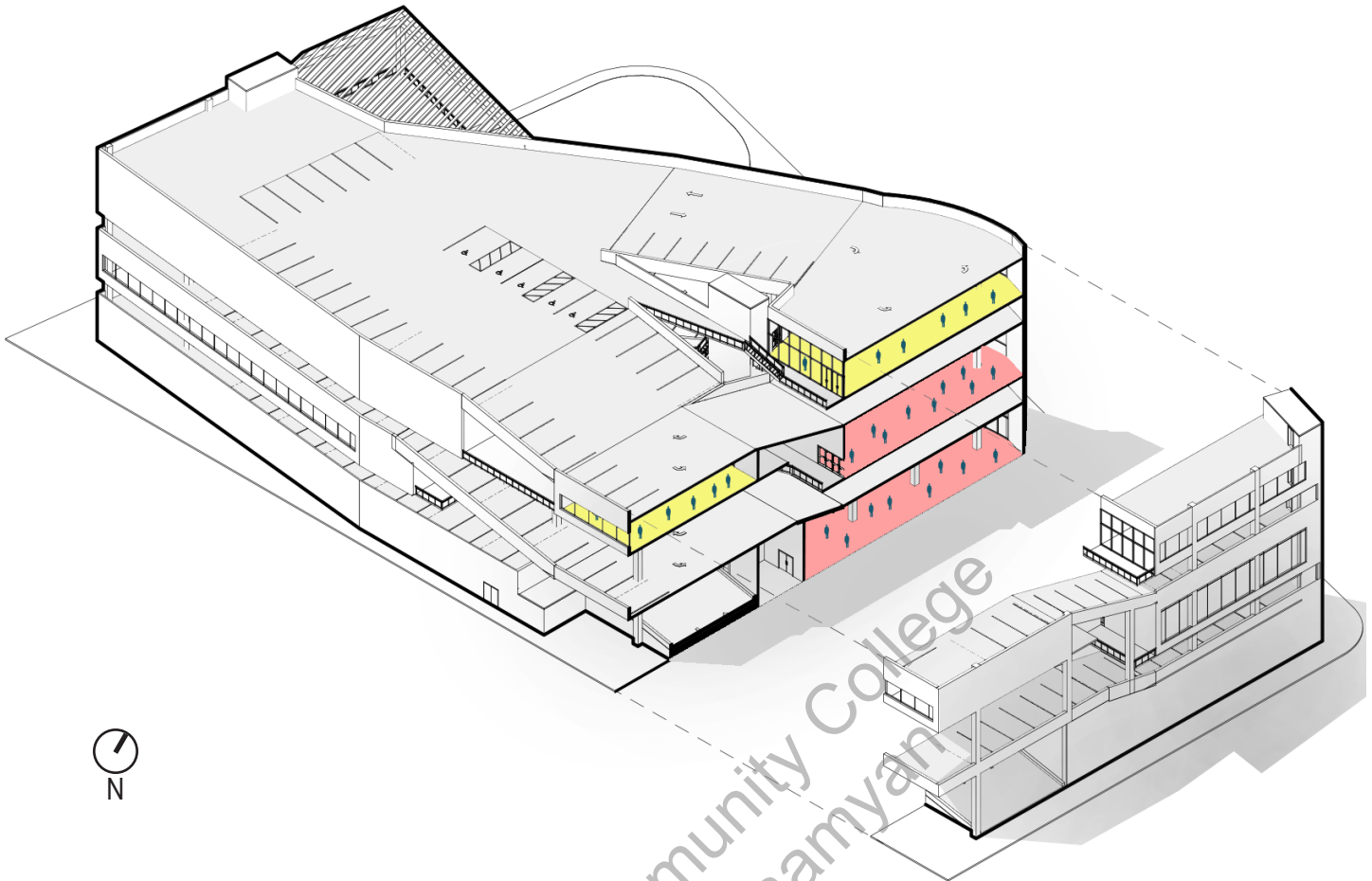

WEST ELEVATION

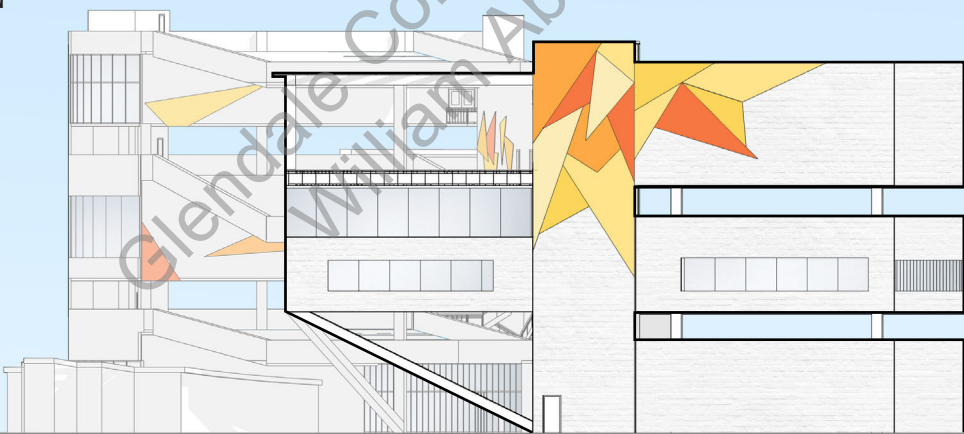

NORTH ELEVATION

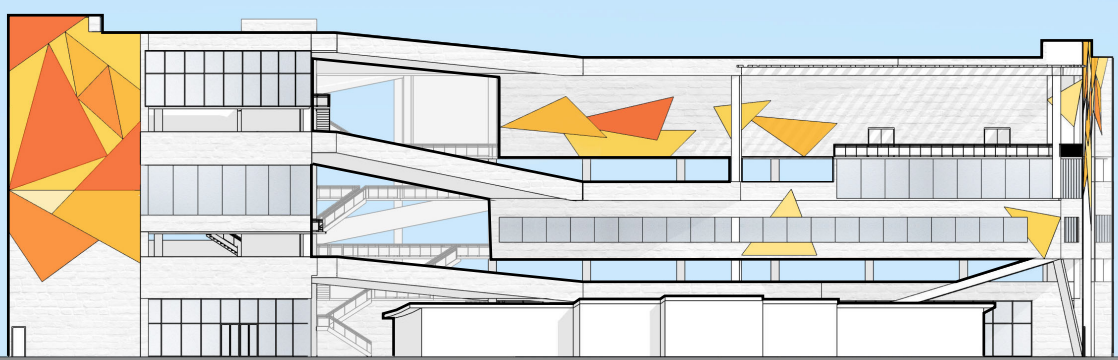

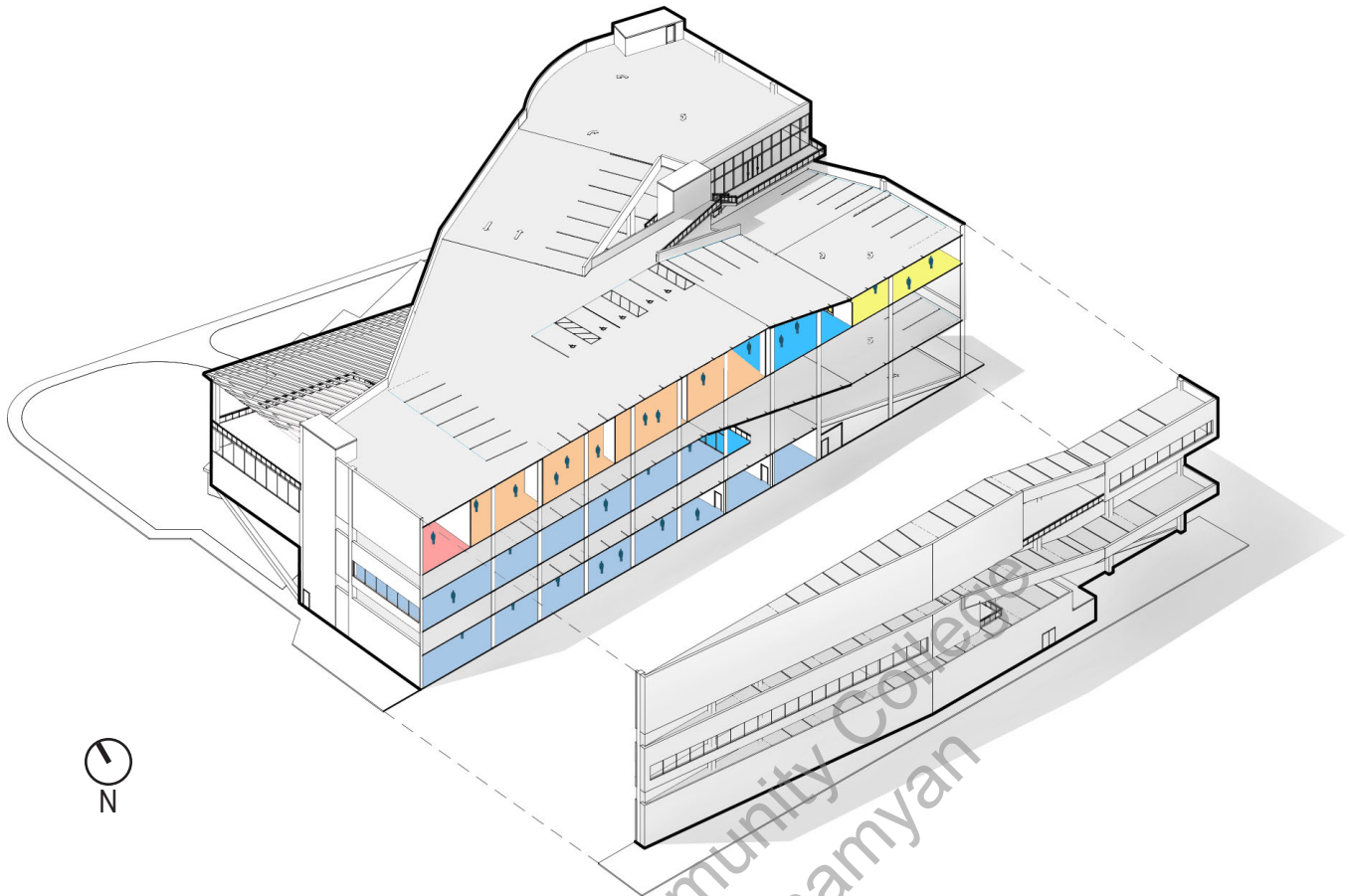

EAST ELEVATION

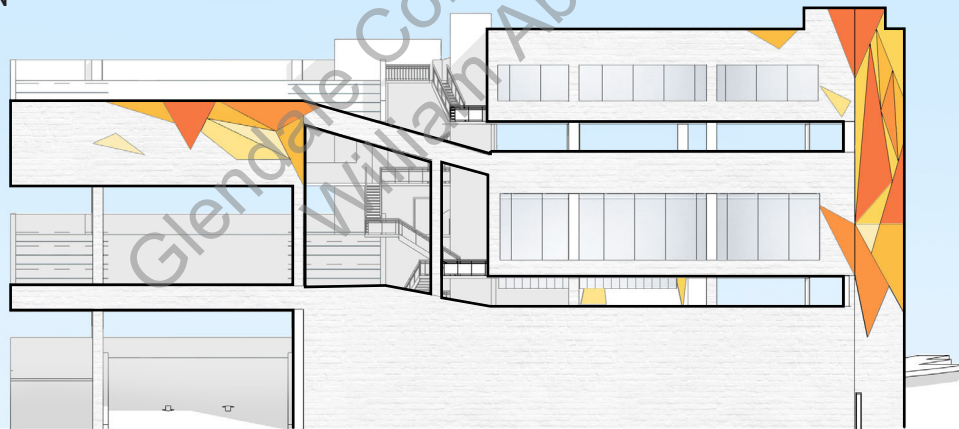

SOUTH ELEVATION

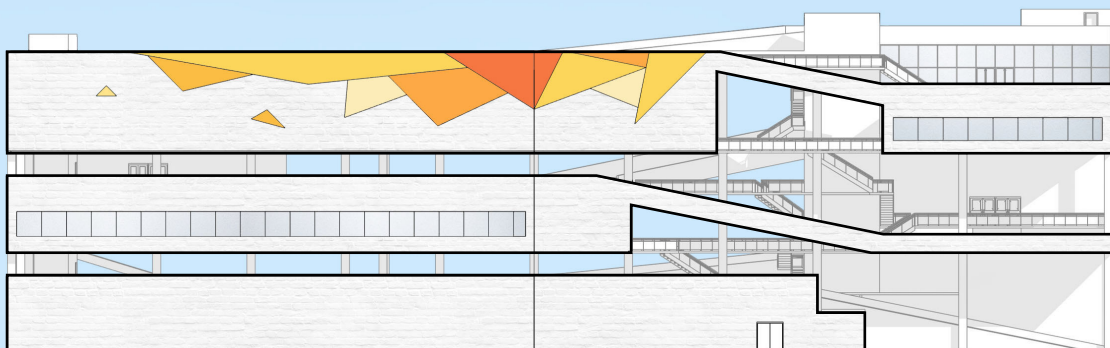

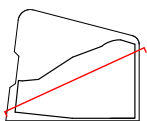
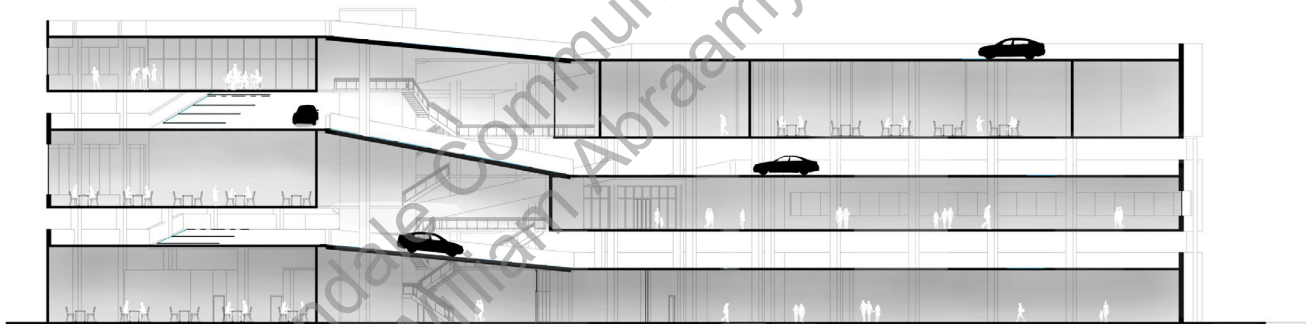

DIAGONAL CUT SECTION

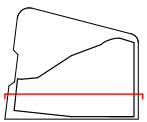
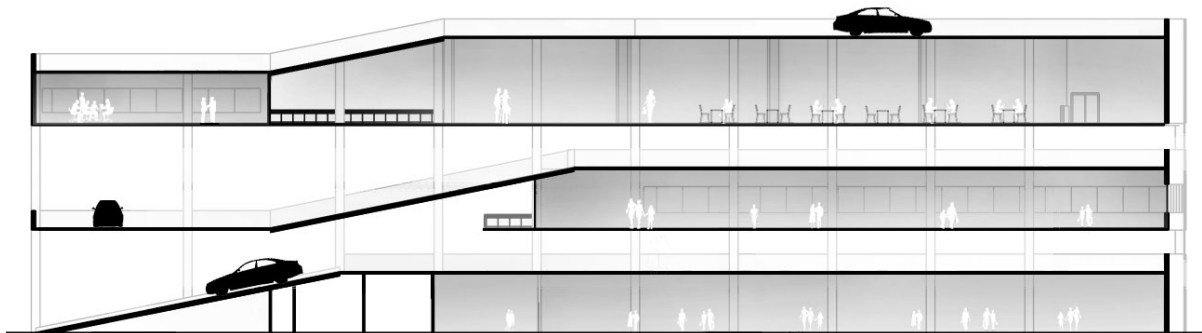

LONGITUDINAL SECTION



OUTDOOR EATING AREA





MACARTHUR PARK MIX USE BUILDING

650 S. ALVARADO ST.
LOS ANGELES, CA



Glendale Community College
William Abraamyan

SECURITY WAS THE TOP PRIORITY WHEN DESIGNING THE BUILDING DUE TO THE BUILDINGS LOCATION. UTILIZING A CENTRALIZED CIRCULATION SYSTEM WITH A SECURITY/LOBBY CHECKPOINT WILL ALLOW TO MONITOR WHO ENTERS AND LEAVES THE BUILDING. WHILE THE PLACMENT OF THE PROGRAMS DICTATE THE LEVEL OF SECURITY NEEDED.

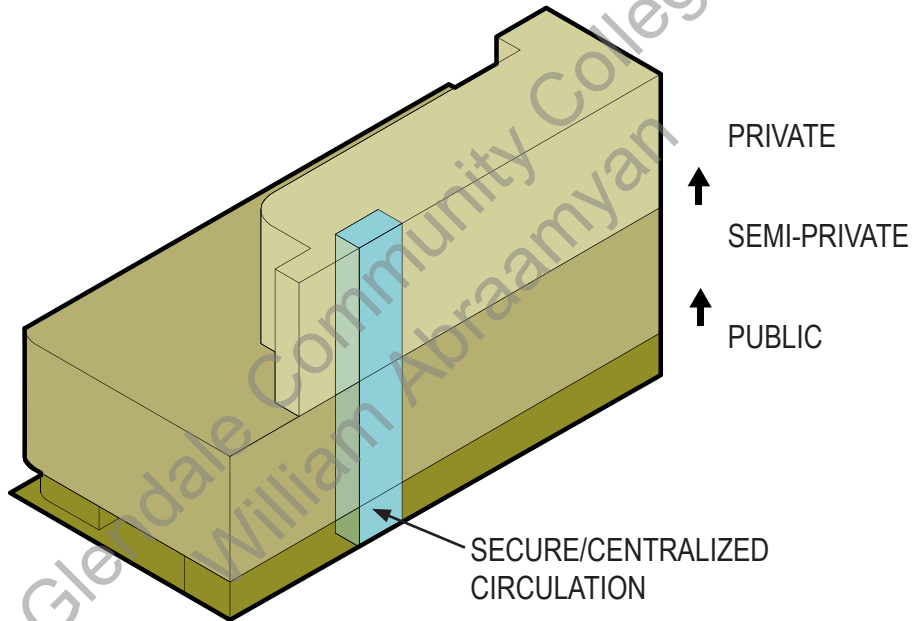
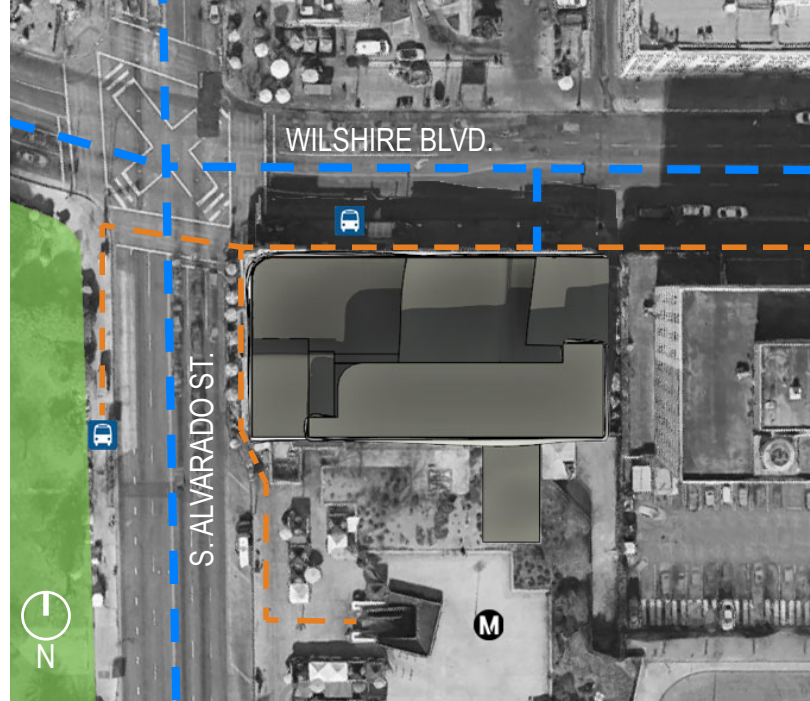

PART I

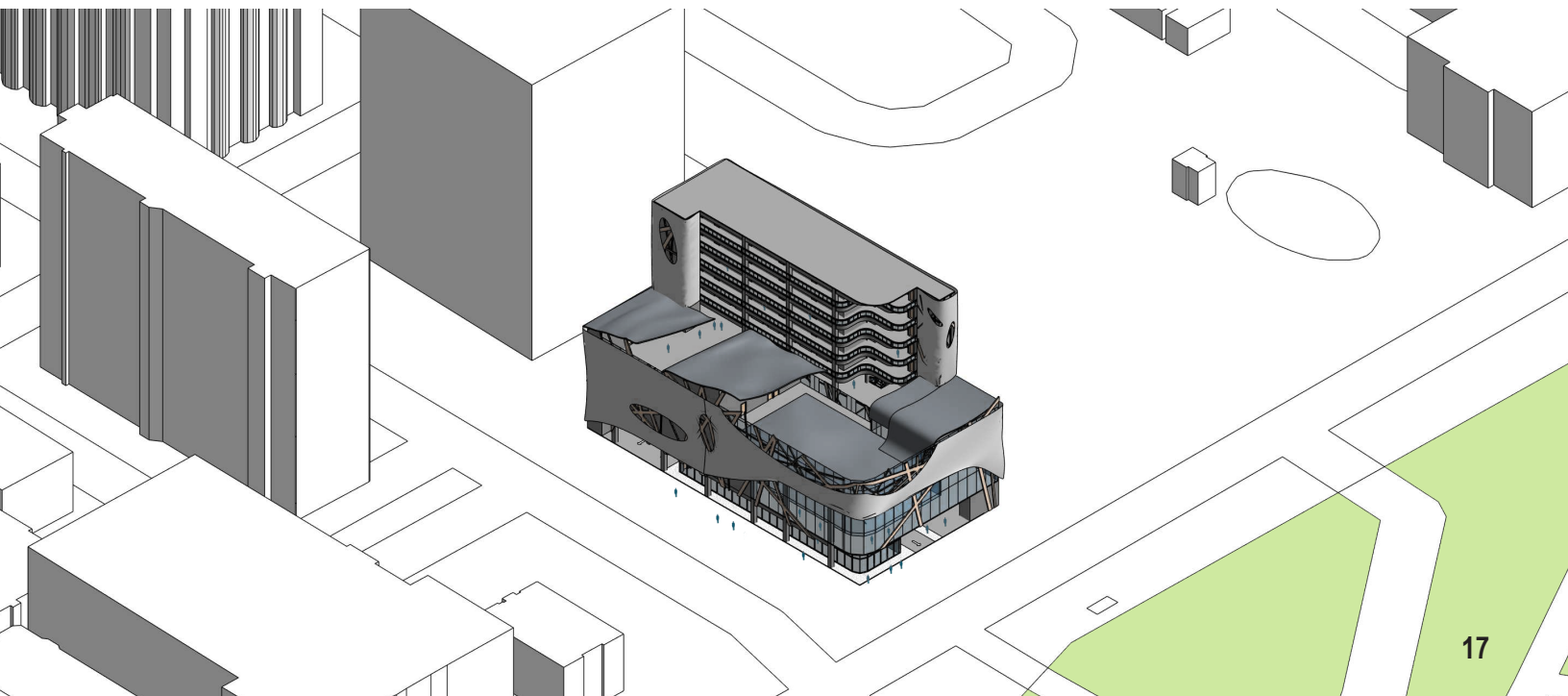

THE NEST LIKE STRUCTURE, WRAPPED AROUND IN WHAT RESEMBLES CLOTH, REPRESENTS THE PRIVACY AND PROTECTION OF THE CHILDREN AND OTHERS OCCUPYING THE BUILDING.

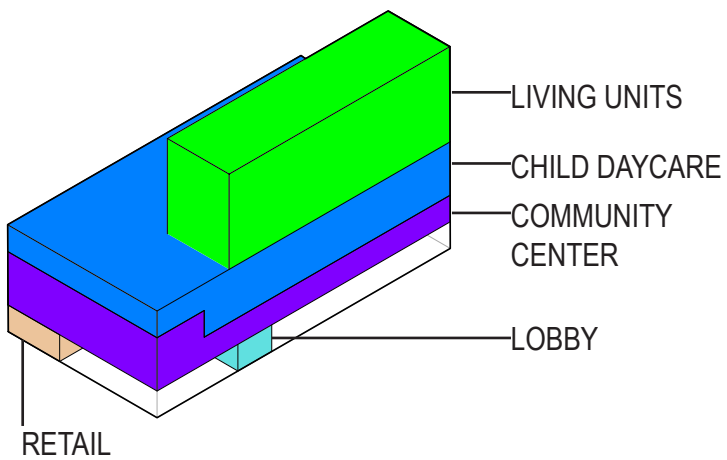

PROGRAM DIAGRAM

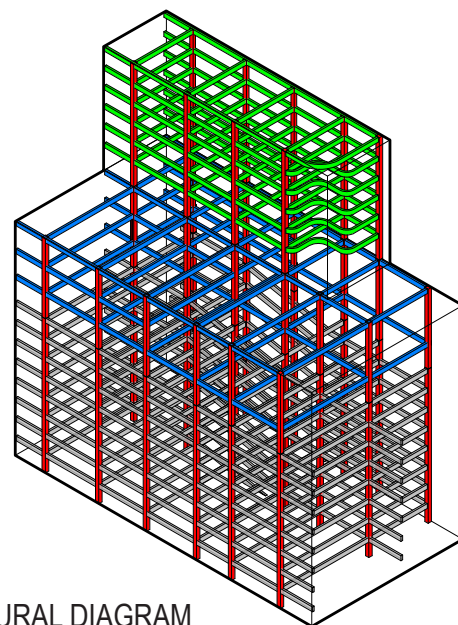

STRUCTURAL DIAGRAM

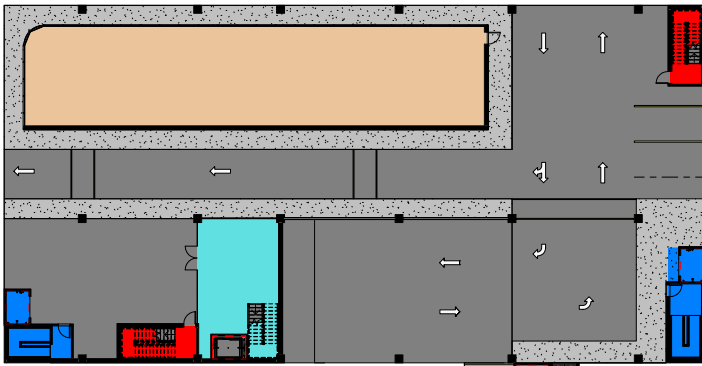

GROUND LEVEL

- LOBBY
- RETAIL
- PARKING CIRCULATION
- METRO STATION CIRCULATION
- FIRE ESCAPE

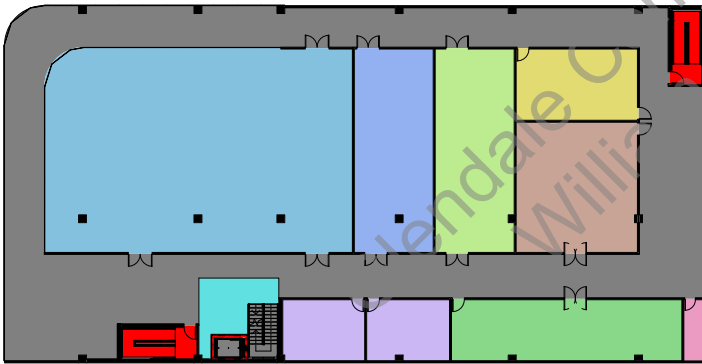

LEVEL 2 - COMMUNITY CENTER

- LOBBY
- RESTROOMS
- KITCHEN
- ASSEMBLY AREA
- MEETING ROOM A
- MEETING ROOM B
- DINING ROOM
- ADMIN OFFICE
- FIRE ESCAPE
- TRASH ENCLOSURE

CIRCULATION TO COMMUNITY CENTER

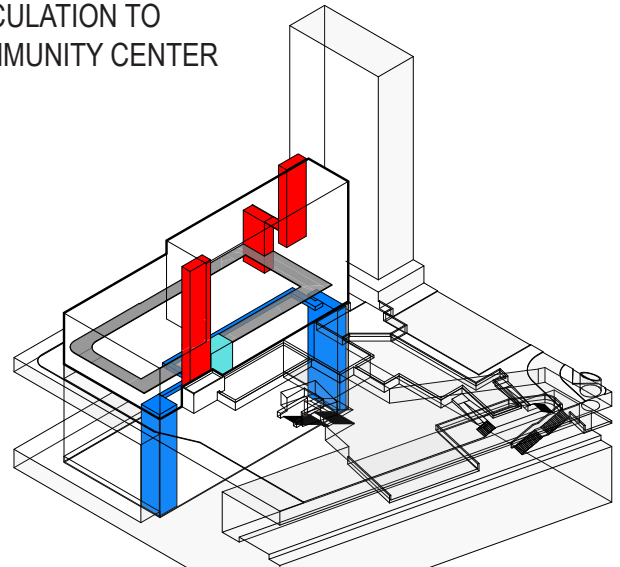

PARKING TO COMMUNITY CENTER

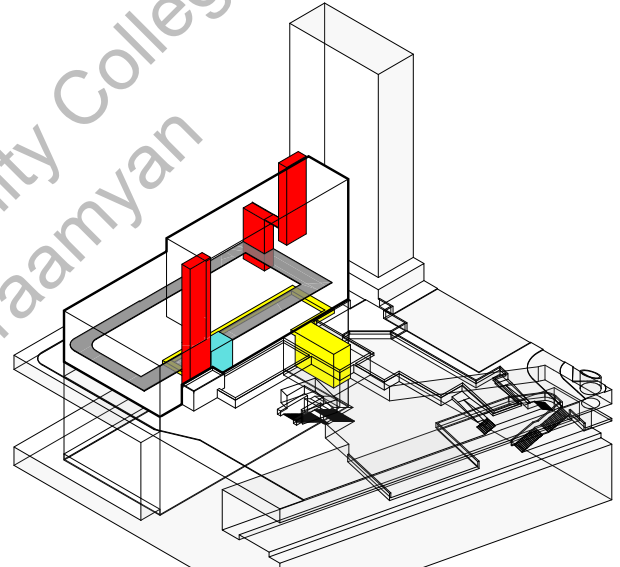

METRO TO COMMUNITY CENTER

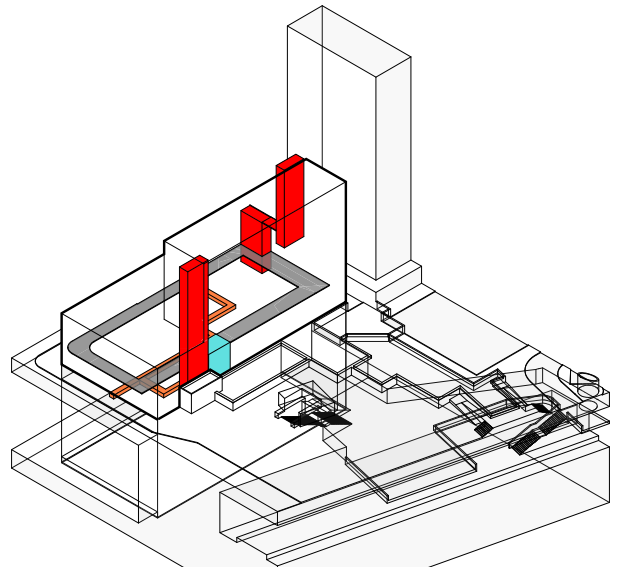

STREET TO COMMUNITY CENTER

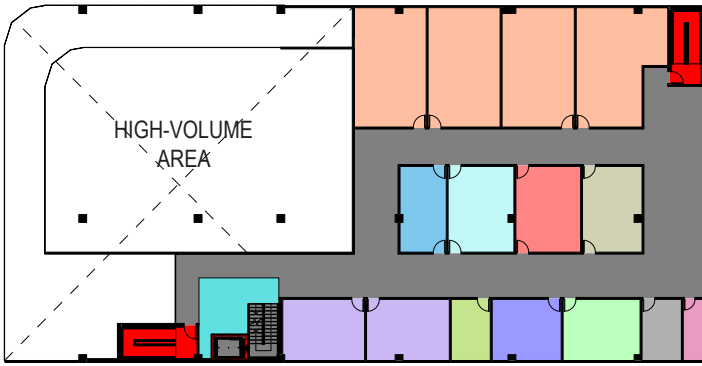

LEVEL 3 - CHILD DAYCARE

- LOBBY
- RESTEROOMS
- DIRECTORS OFFICE
- STAFF LOUNGE
- PANTRY
- LAUNDRY
- TRASH CHUTE
- SICKBAY
- PARENTS ROOM
- STAFF OFFICE
- STORAGE
- CLASSROOMS
- FIRE ESCAPE

CIRCULATION TO CHILD DAYCARE CENTER

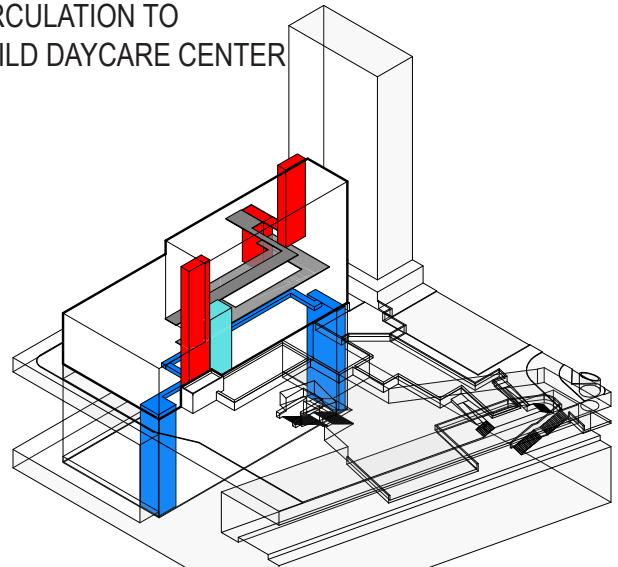

PARKING TO CHILD DAYCARE CENTER

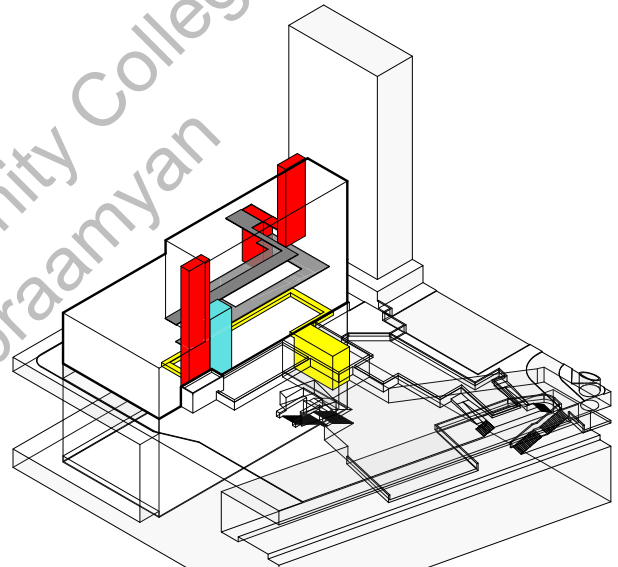

METRO TO CHILD DAYCARE CENTER

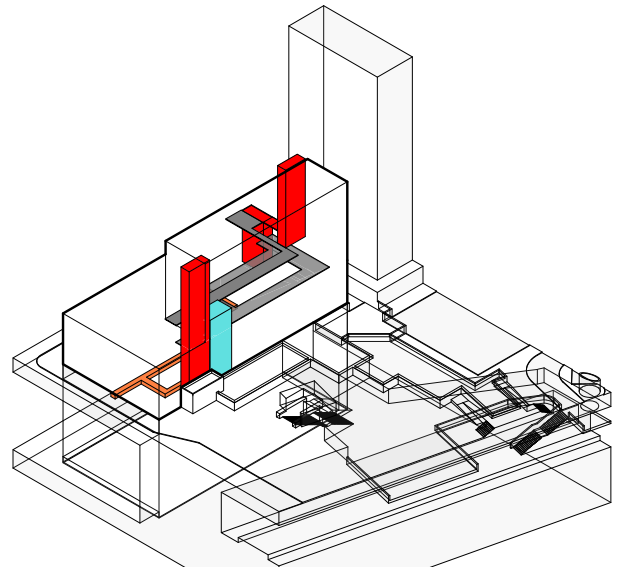

STREET TO CHILD DAYCARE CENTER

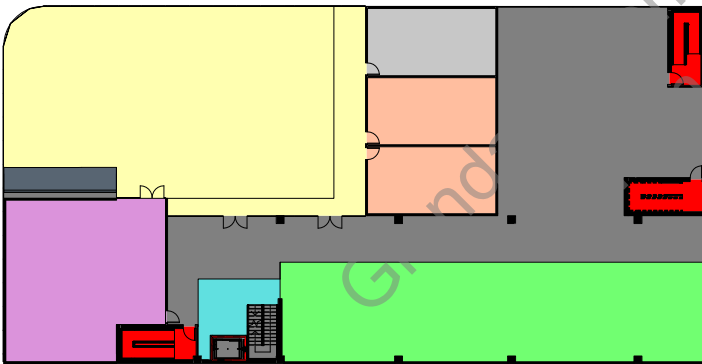

LEVEL 4 - CHILD DAYCARE

- LOBBY
- CLASS ROOM
- MULTI-PURPOSE STORAGE
- INDOOR PLAY AREA
- OUTDOOR PLAY AREA
- OUTDOOR AREA
- FIRE ESCAPE

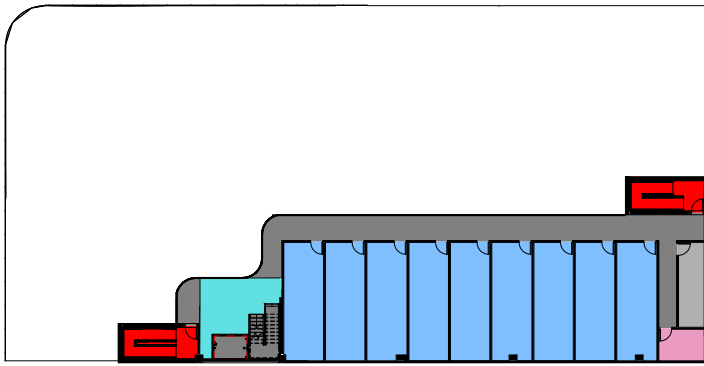

LEVEL 5 - LIVING UNITS

- LOBBY
- 1 BEDROOM MICRO UNIT
- TRASH CHUTE
- LAUNDRY
- FIRE ESCAPE

CIRCULATION TO LIVING UNITS

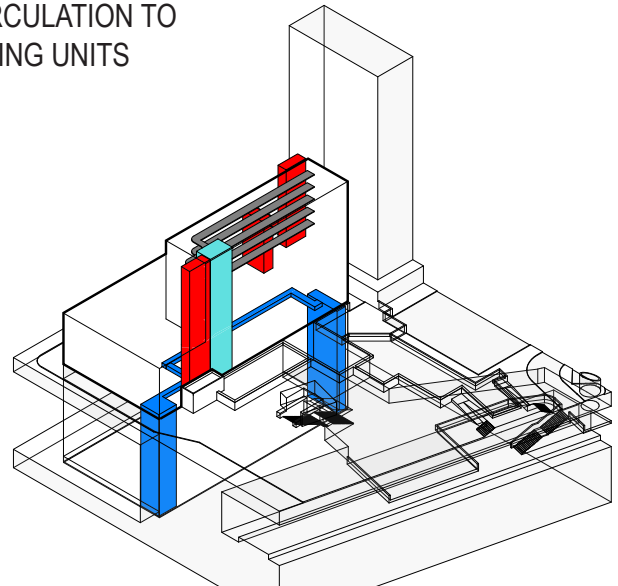

PARKING TO LIVING UNITS

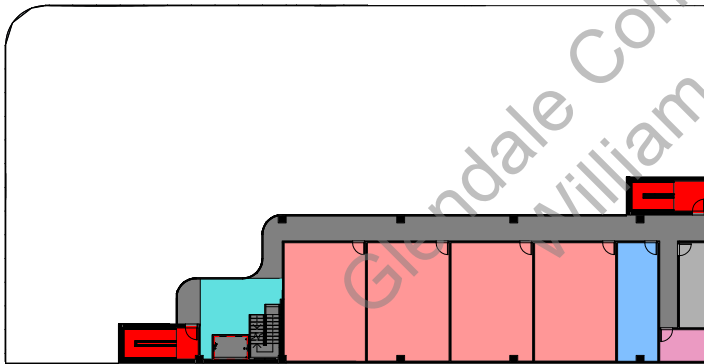

LEVEL 6-9 - LIVING UNITS

- LOBBY
- 2 BEDROOM LIVING UNIT
- 1 BEDROOM MICRO UNIT
- TRASH CHUTE
- LAUNDRY
- FIRE ESCAPE

METRO TO LIVING UNITS

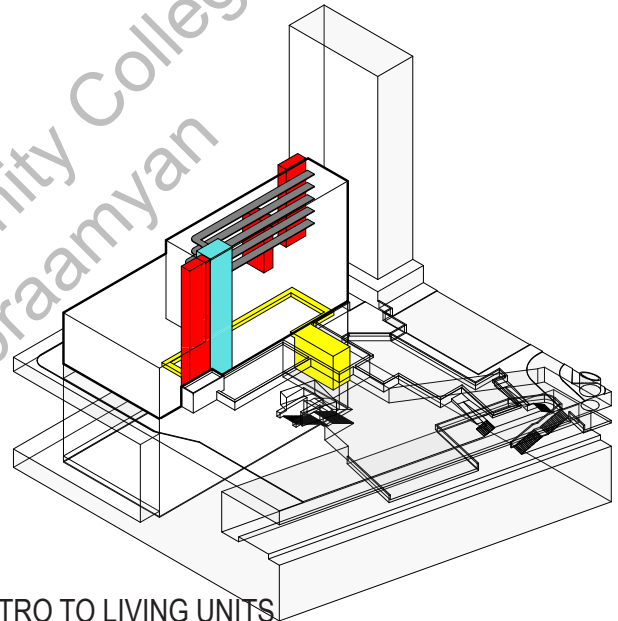

STREET TO LIVING UNITS

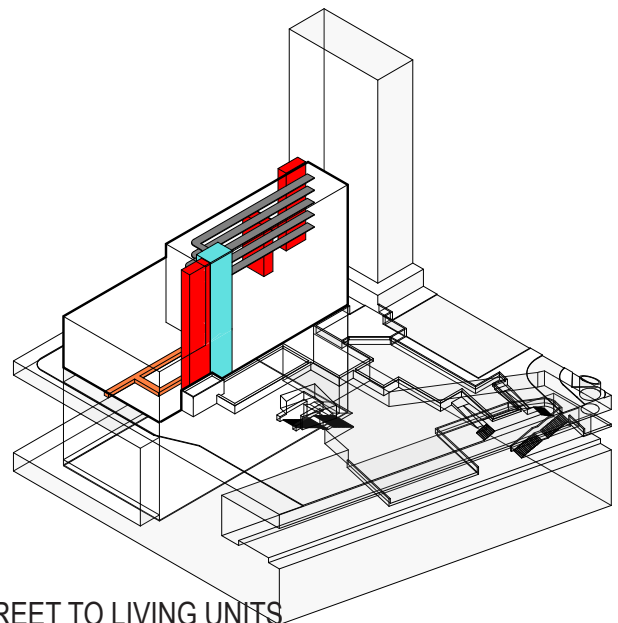

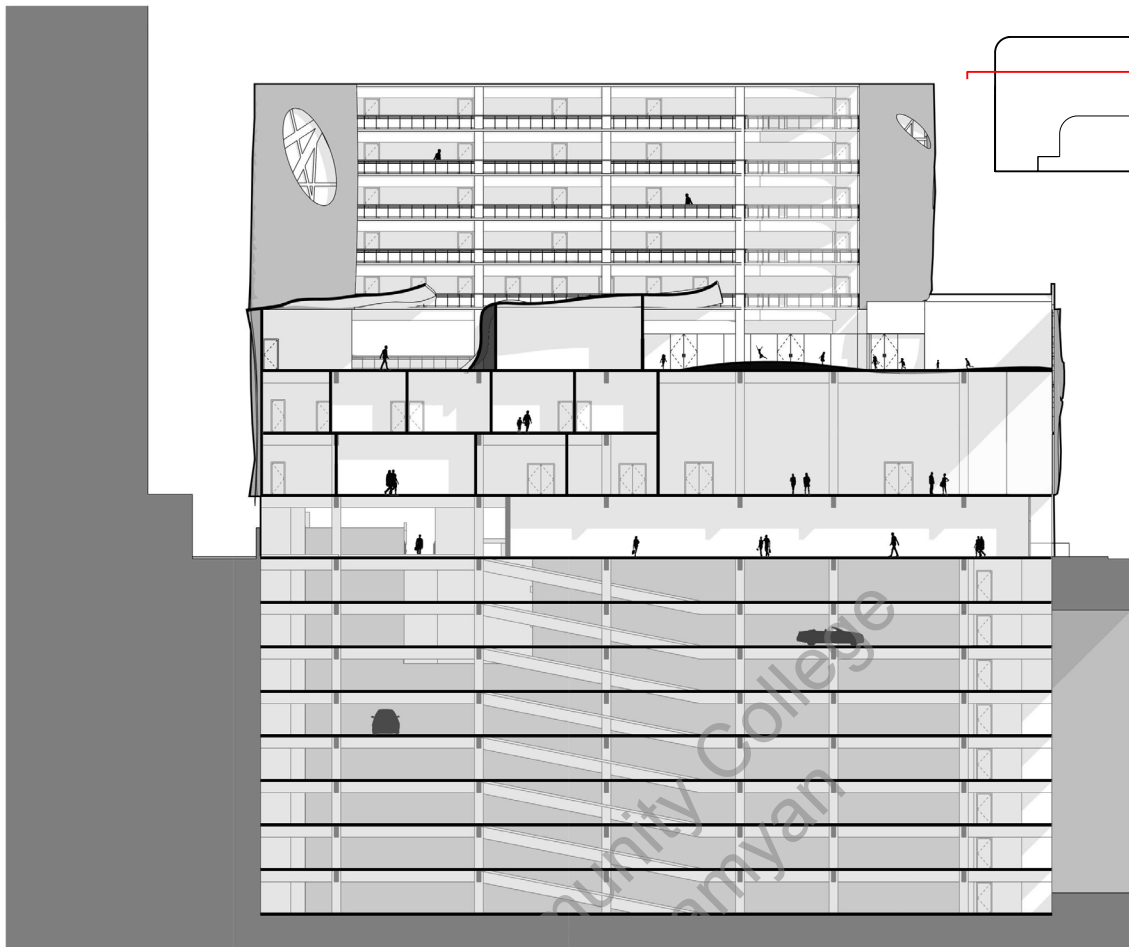

LONGITUDINATL SECTION / NORTH ELEVATION

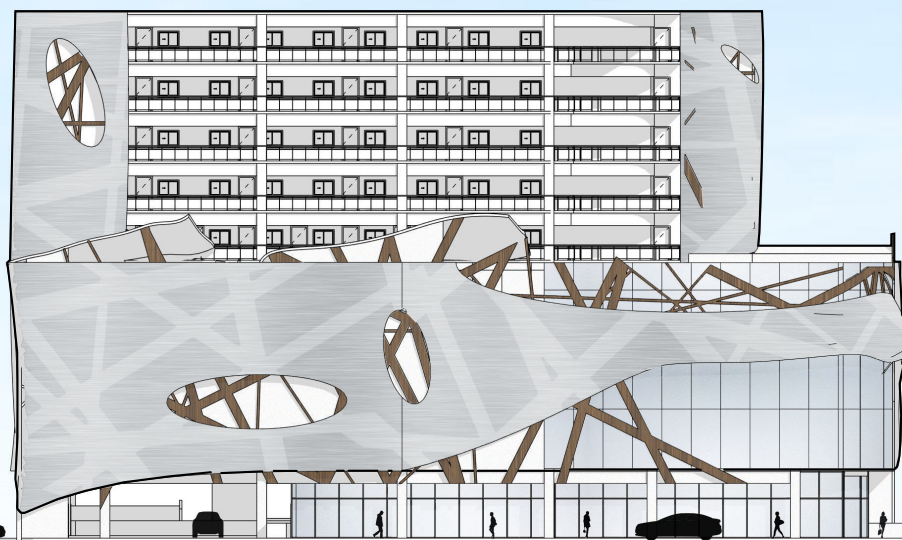

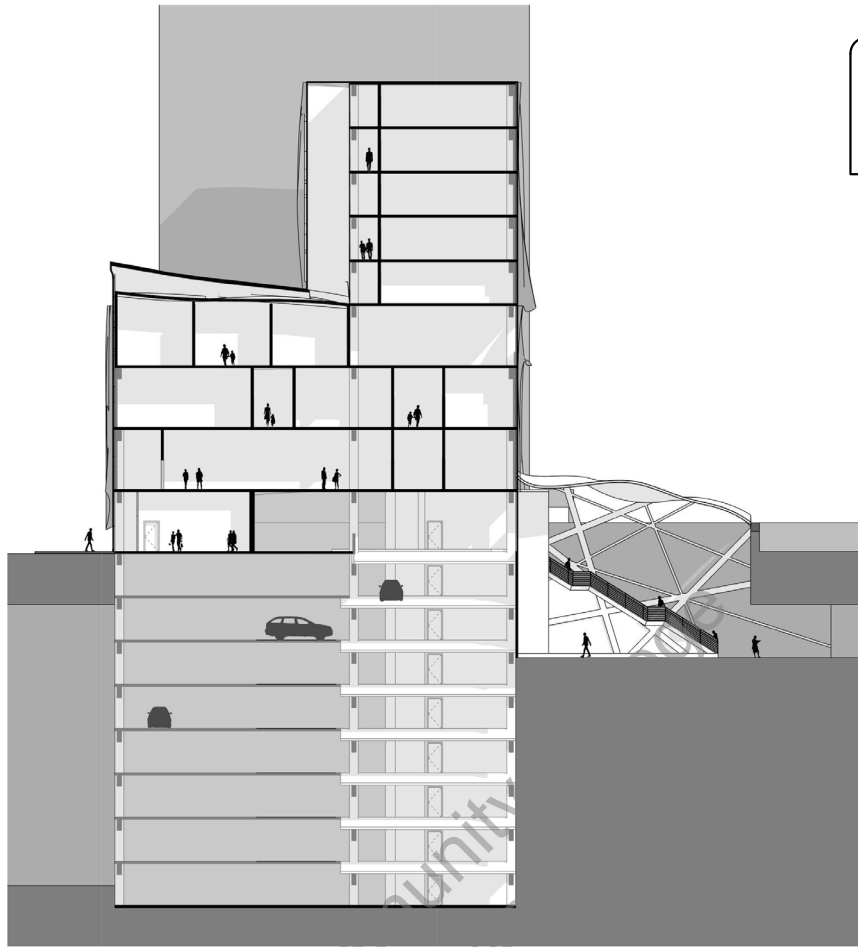

CROSS SECTION / WEST ELEVATION





OUTDOOR AREA
SOUTH ELEVATION

Glendale Community College
William Abraamyan

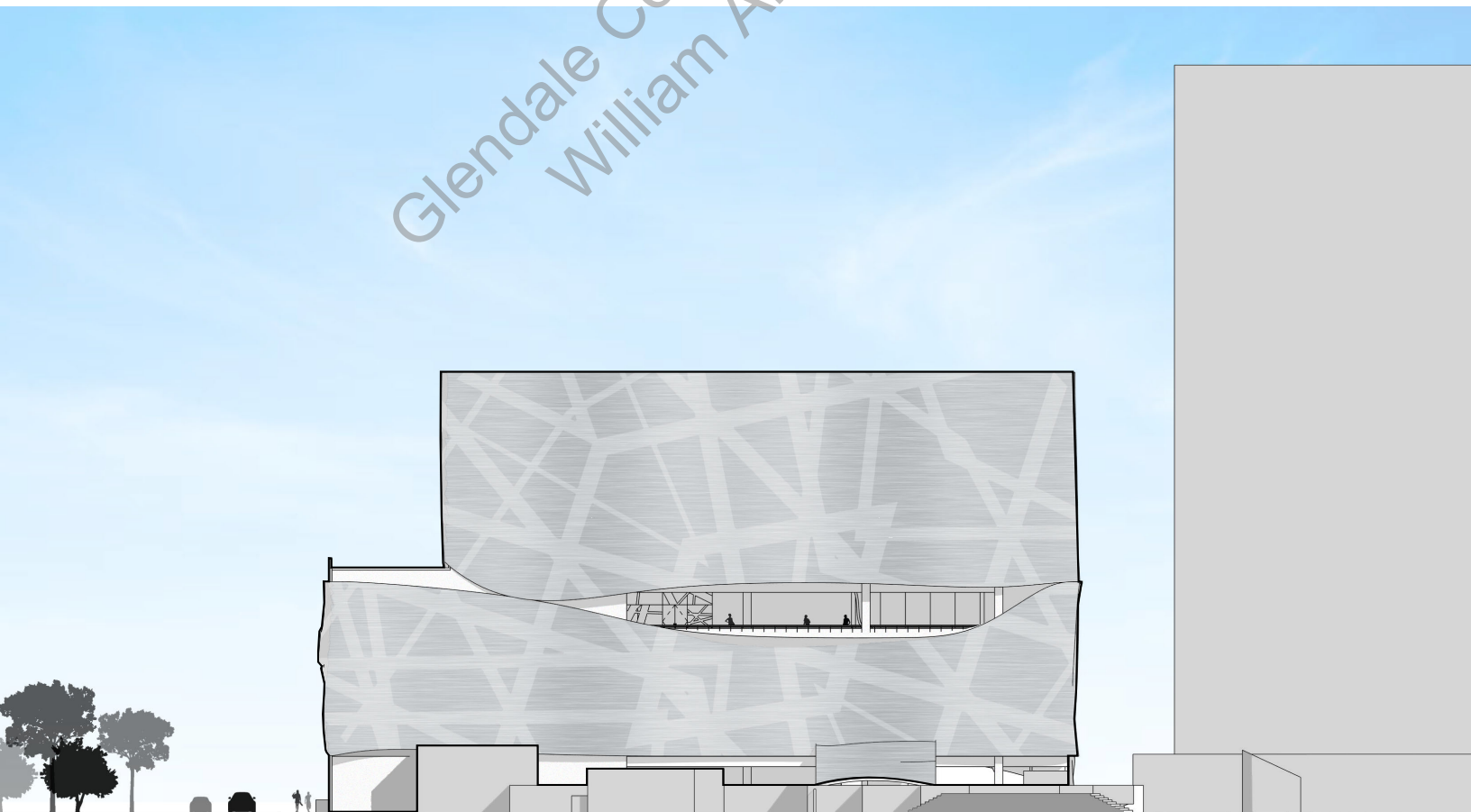



LOBBY / DROP-OFF ZONE
EAST ELEVATION

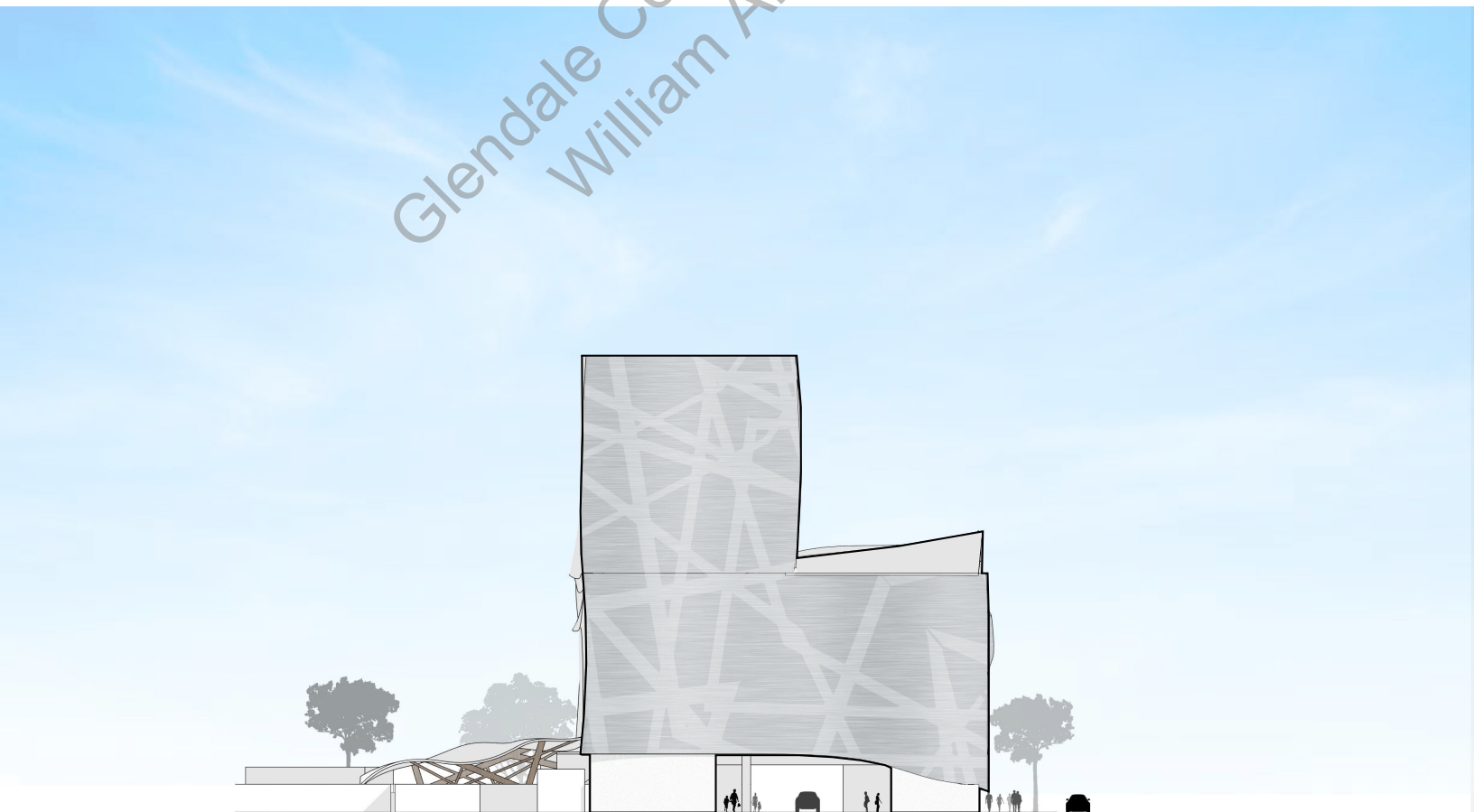

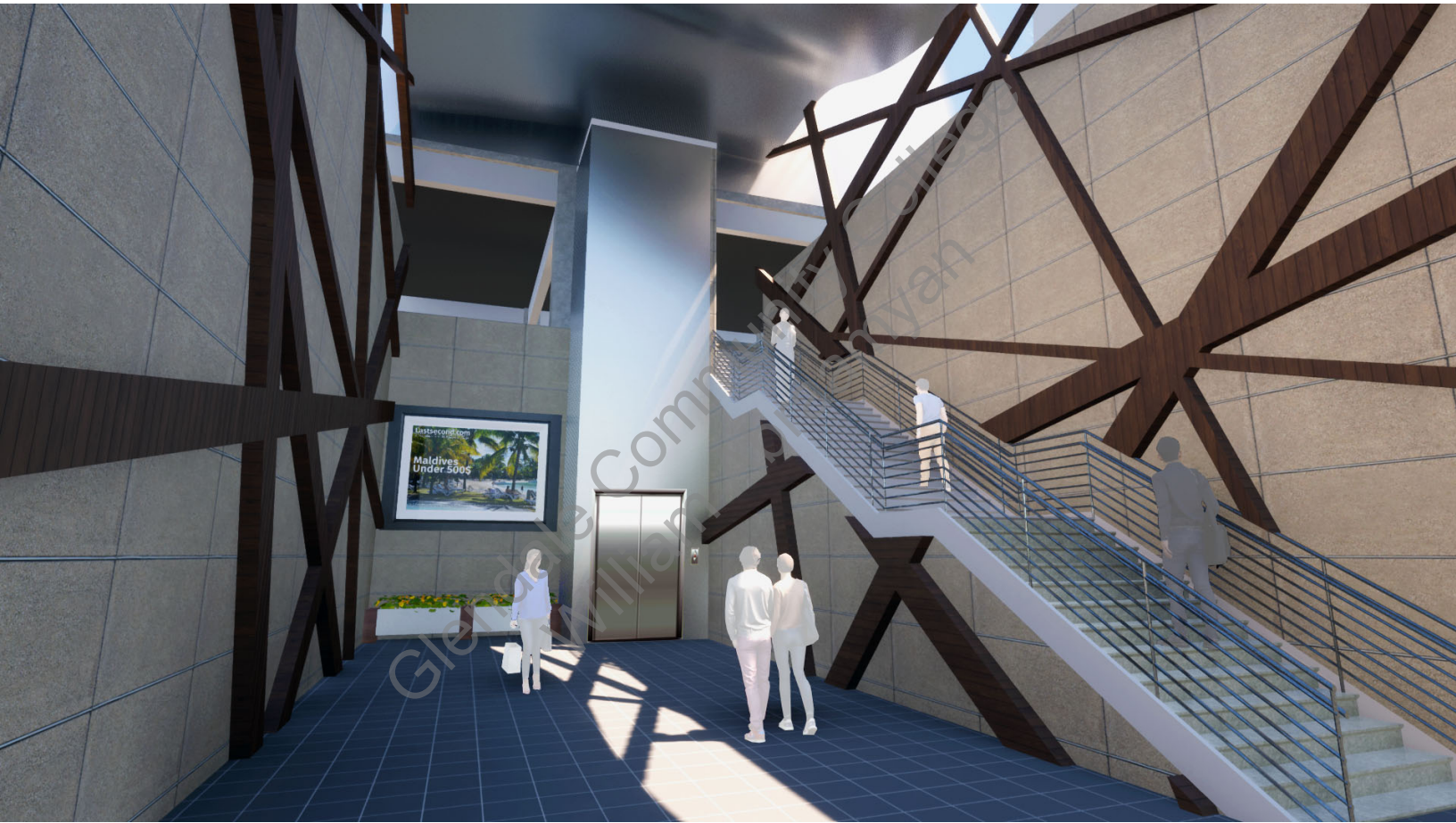

ENTRANCE FROM METRO

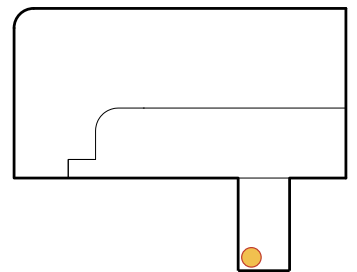



VIEW OF MACARTHUR PARK

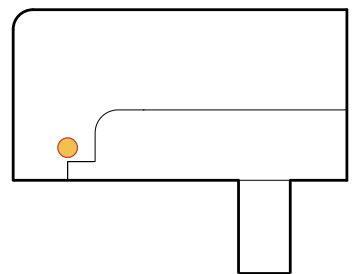

HOUSE FOR A BLIND PERSON

708 E. PALMER AVE.
GLENDALE, CA



THE GOAL OF THIS HOUSE WAS TO DESIGN A HOME TO SIMPLIFY THE CIRCULATION PATH OF THE PERSON OCCUPYING THE SPACE.

THE "LEFT HAND/RIGHT HAND" CIRCULATION, ALONG WITH THE ELIMINATION OF CORNERS WILL ALLOW THE TENNANT TO KNOW EXACTLY WHERE THEY ARE AND WHERE THEY ARE HEADED WITHOUT RUNNING INTO ANY OBSTACLES.

THE USE OF LIGHTING, SOUND, AND MATERIALS ARE ALSO USED TO AID THE BLIND PERSON IN THE HOME.

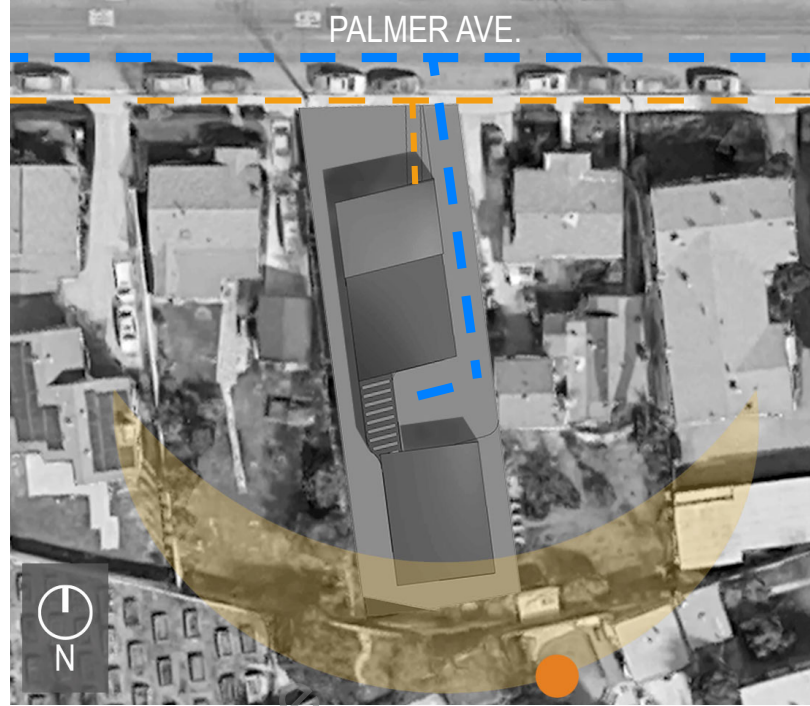

PARTI

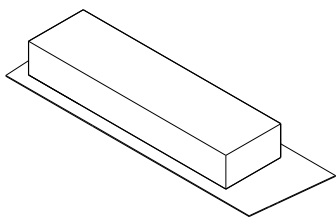

BASIC SHAPE

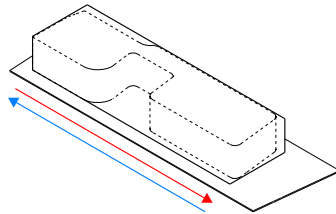

ROUNDED WALLS FOR LEFT HAND/RIGHT HAND CIRCULATION

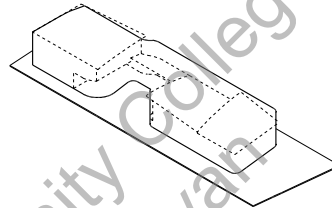

SHAPING CONCAVE CEILINGS

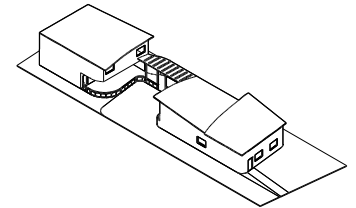

FINAL DETAILING

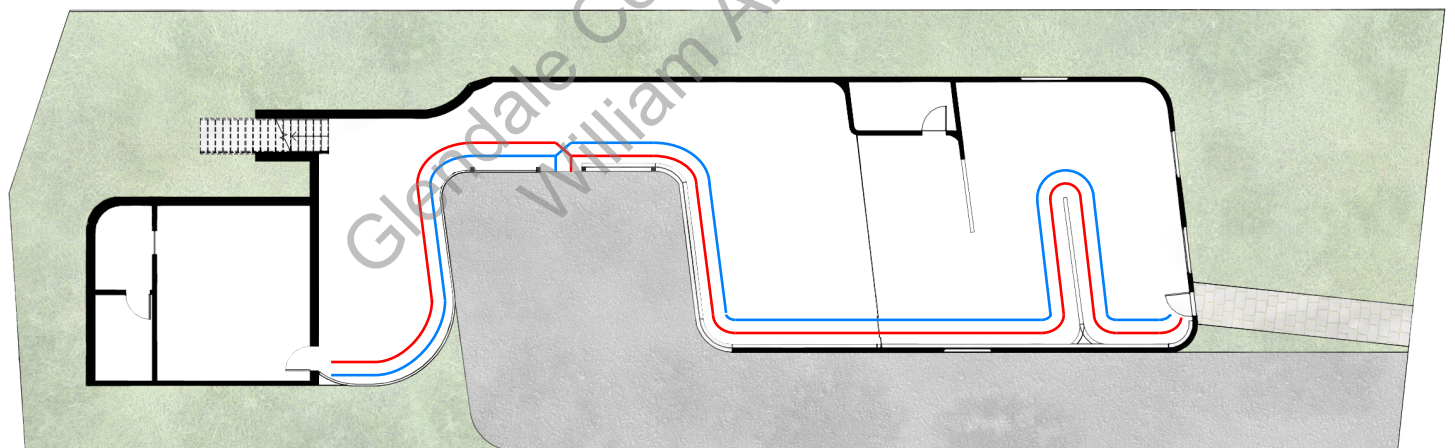

WALKING WITH THE LEFT HAND ALONG THE CIRCULATION WALL WILL GET YOU TO THE BACK OF THE HOUSE. ■

WALKING WITH THE RIGHT HAND ALONG THE CIRCULATION WALL WILL GET YOU TO THE FRONT OF THE HOUSE. ■



3-D PRINTED MODEL OF FLOOR PLAN

THE BLIND CLIENTS WILL HAVE THE OPORTUNIRY TO FEEL AND UNDERSTAND THE FLOOR PLAN OF THE HOME.

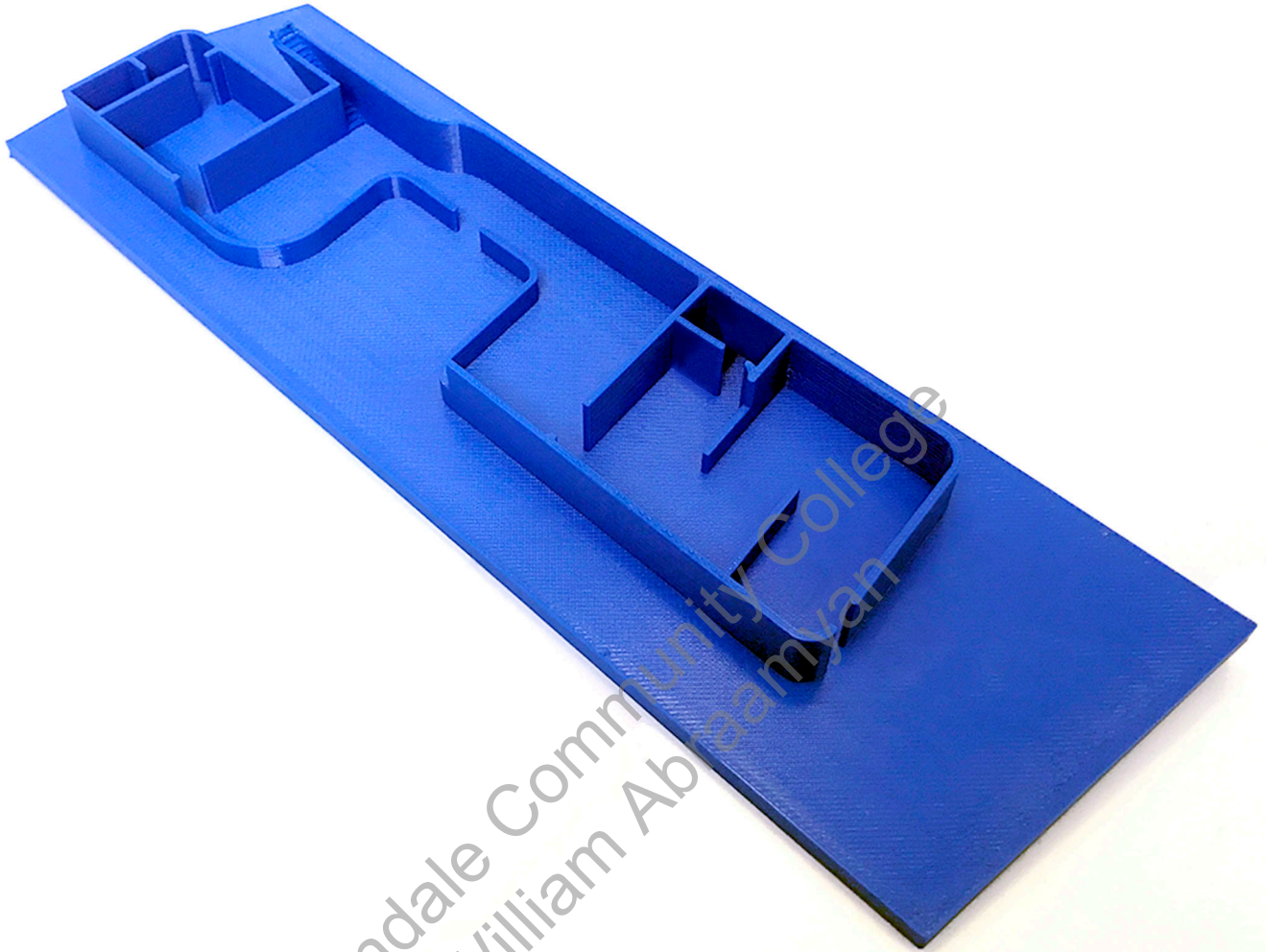

Glendale Community College
William Abrahamyan



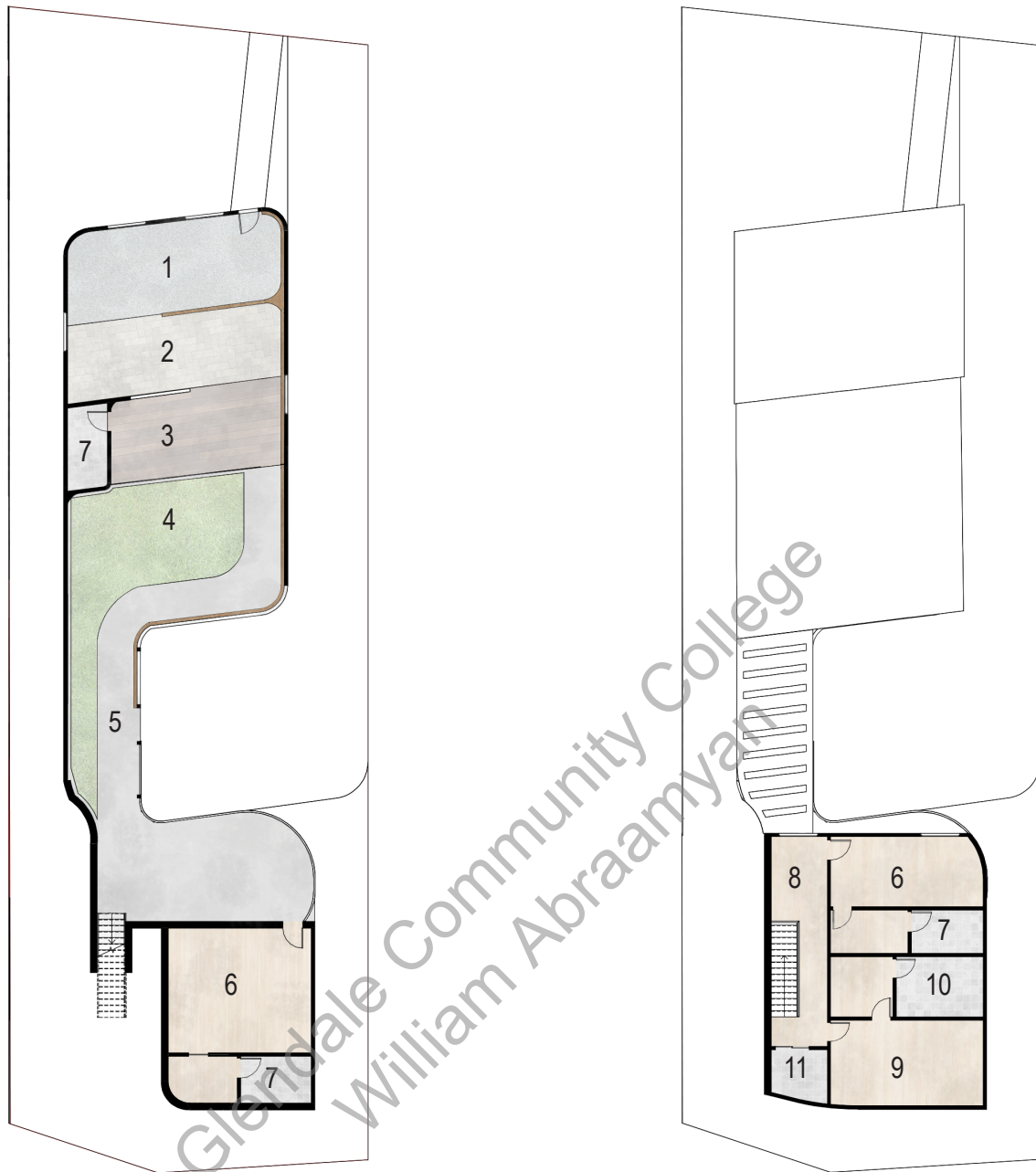

THE BLIND PERSON'S BEDROOM IS LOCATED ON THE FIRST FLOOR TO MINIMIZE THE USE OF STAIRS.

FIRST FLOOR:

- 1 - LIVING ROOM.....CARPET
- 2 - KITCHEN.....TILE
- 3 - FAMILY ROOM.....HARDWOOD
- 4 - COURTYARD.....VEGITATION
- 5 - WALKWAY.....CONCRETE
- 6 - BEDROOM/
WALK IN CLOSET.....HARDWOOD
- 7 - BATHROOM/
POWDER ROOM.....TILE

SECOND FLOOR:

- 6 - BEDROOM/ WALK IN CLOSET
- 7 - BATHROOM/ POWDER ROOM
- 8 - HALLWAY
- 9 - MASTER BEDROOM
- 10 - MASTER BATHROOM
- 11 - LAUNDRY ROOM



NORTH ELEVATION

SOUTH ELEVATION

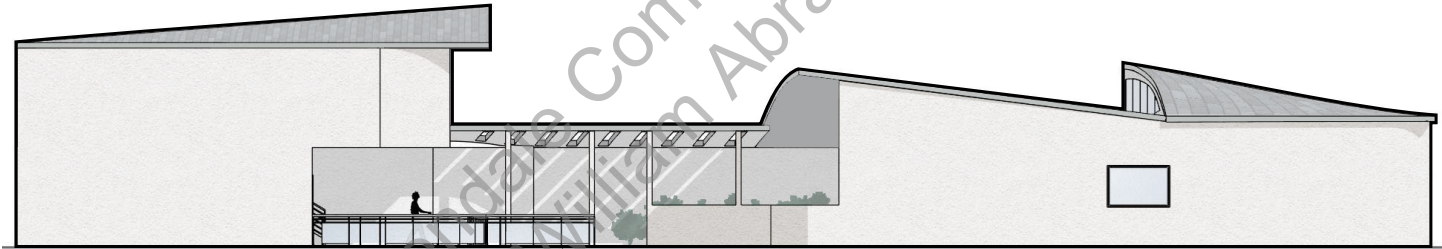

EAST ELEVATION

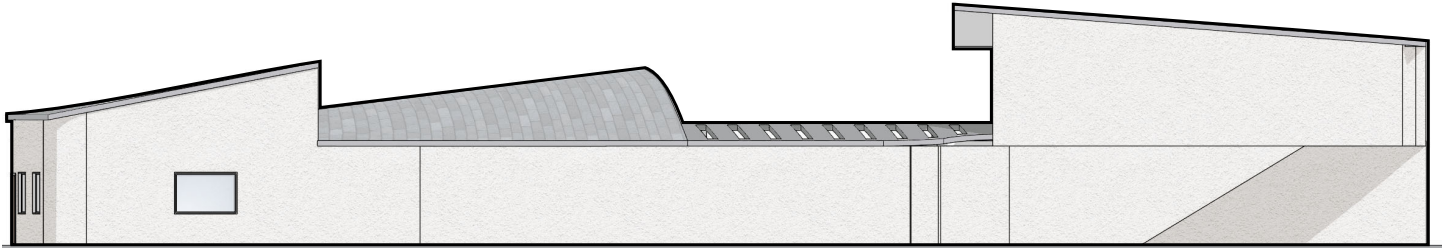

WEST ELEVATION

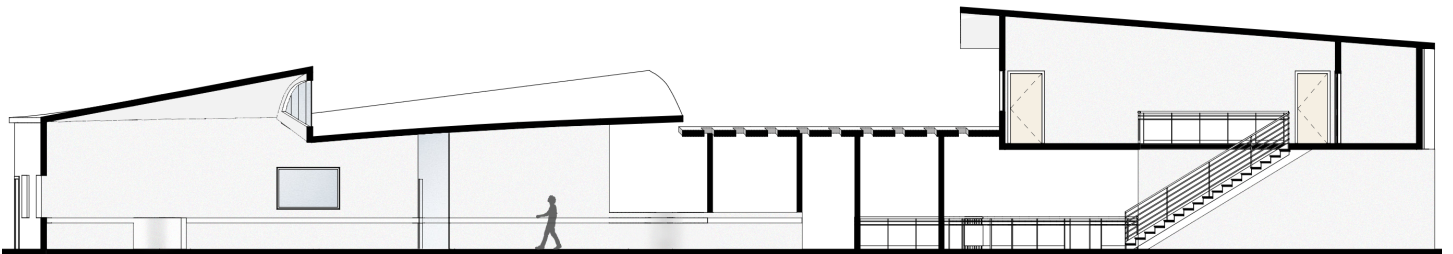
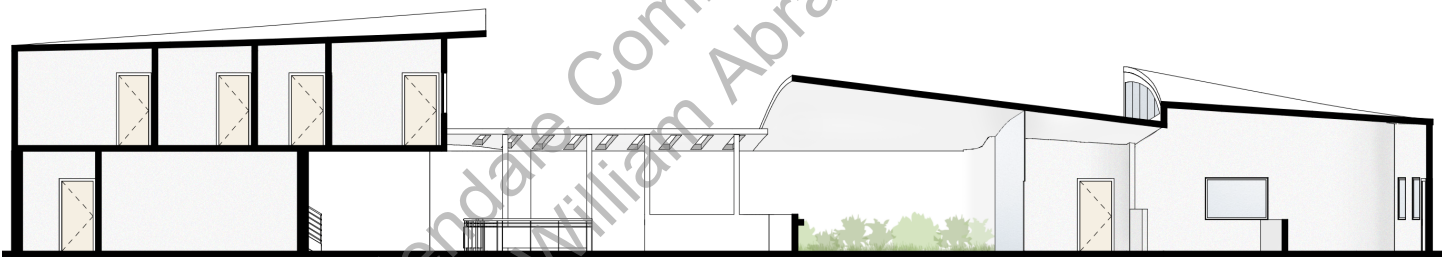
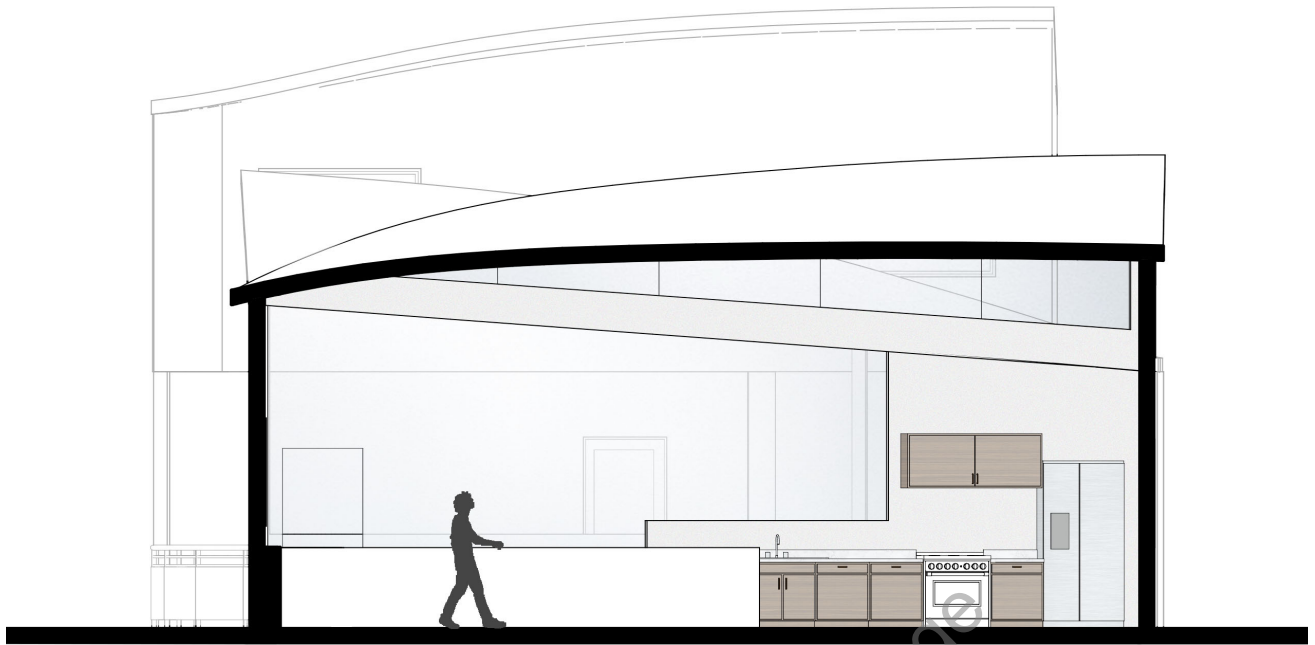

Glendale Community College
William Abraamyan

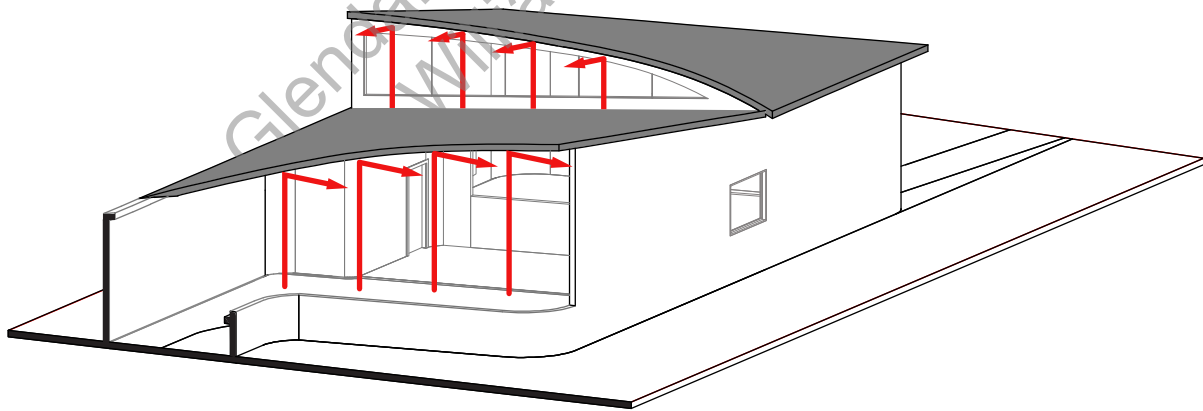

THE CONCAVE ROOF ALLOWS FOR SOUND TO BE FOCUSED IN CERTAIN AREAS OF THE LIVING AREA.

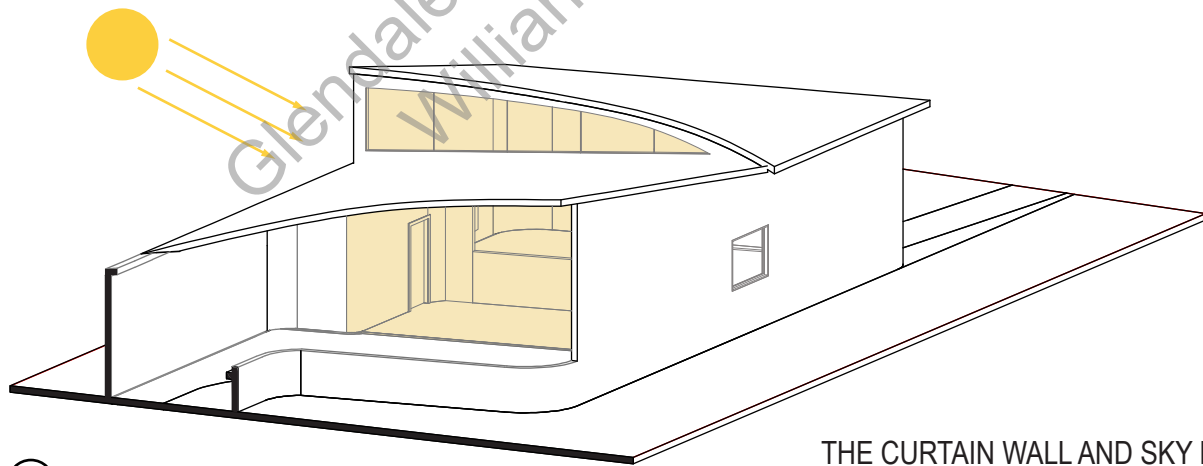

THE CURTAIN WALL AND SKY LIGHT ALLOW LIGHT TO ENTER THE SOUTH END, BRIGHTENING UP THE LIVING AREA.

THE OVERHANG BLOCKS DIRECT SUNLIGHT, HELPING THE ROOM STAY A LITTLE COOLER.

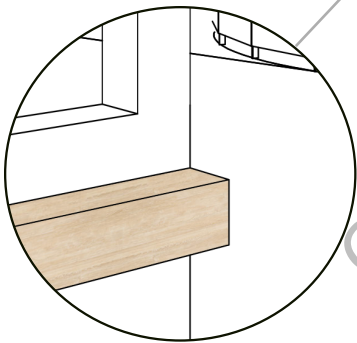
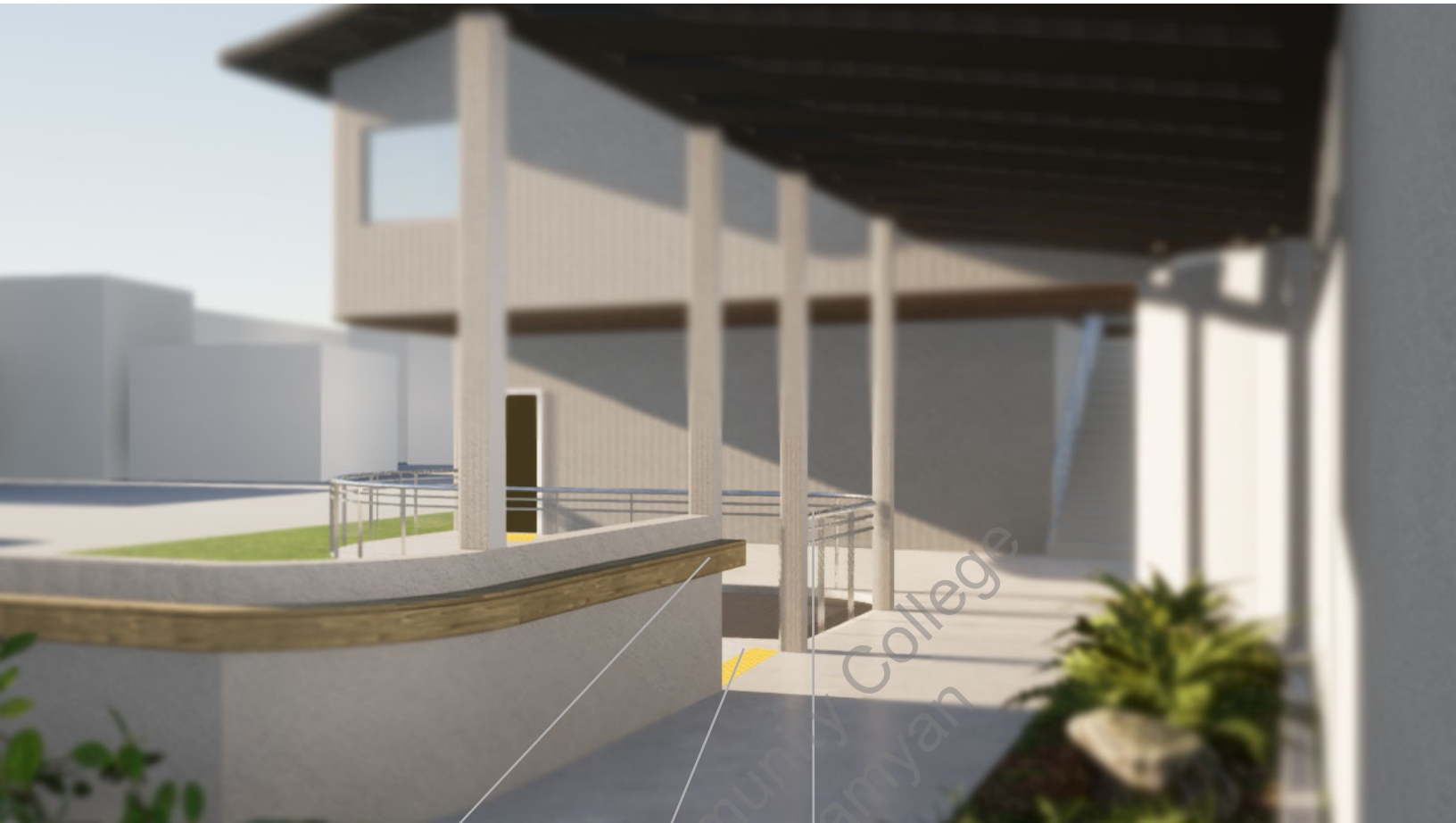

THE SMOOTH WOODEN RAIL REPRESENTS THE PUBLIC HALF OF THE HOME.

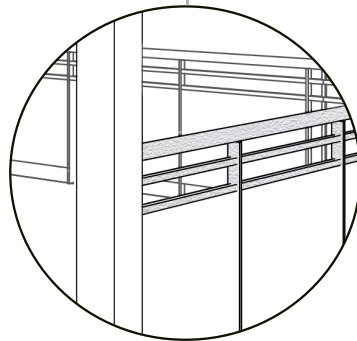

THE TEXTURED VINYL RAILING REPRESENTS THE PRIVATE HALF OF THE HOME.

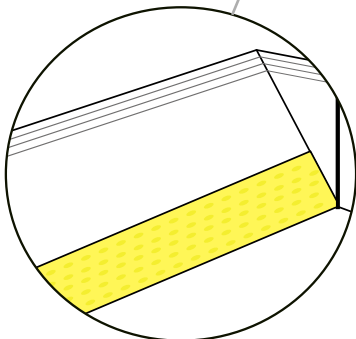

TACTILE FLOORING IS ALSO USED TO AID IN IDENTIFYING LEVEL CHANGES AND DOORWAYS.



Glendale Community College
William Abraamyan

THANK YOU